

XLPE Cable Type Current Transformers User Manual



**ADDRESS: Ikitelli OSB Mah. Cevre
14. Blok Sok. Telas Blok Dis Kapi
No: 1 Kat: 1-2 Basaksehir/Istanbul**

**Phone: +90 212 438 80 24
Fax: +90 212 438 80 25**

info@gruparge.com

CONTENTS

PROPER USE AND SAFETY CONDITIONS	3
1. INTRODUCTION	4
1.1. General Features	4
1.2. Technical Features	4
1.3. Technical Drawing	5
1.4. Connection Diagrams	5
1.4.1. Medium Voltage Reference System Connection Diagram Example	5
1.4.2. XLPE Cable Type Current Transformers Connection Diagram	6
1.4.3. Connection Types Between Current Transformer and Earthing Cables ..	6
1.4.4. XLPE Cable Type Current Transformer - Secondary Cable Cross- Sections (mm ²)	6

PROPER USE AND SAFETY REQUIREMENTS



Cut all the power when connecting and disconnecting the device to a panel.



Do not clean the device with a solvent or similar material. Only use a dry cloth.



Please do not intervene to the device when a technical problem is encountered and get in contact with a technical service within the shortest time.



If the warnings are not taken into account, our company or the authorized dealer shall not be held responsible for the negative consequences.



Do not dispose in the trash, the device must be delivered to the collection centers (electronic device recycling centers). It should be recycled or disposed of without harming human health and environment.



The installation, assembly, activation and operation of the device should be done and used by only expert professionals and in accordance with safety regulations and instructions.

1. INTRODUCTION

1.1. General Features

XLPE Cable Type Current Transformers are used in systems where current measurements are taken by medium voltage and power factor controllers, capacitors, and shunt reactor compensators are located on the low voltage side.

Especially in businesses where the meter is located at medium voltage, traditional compensation systems designed for high power cannot provide sufficient measurement and response sensitivity under low consumption conditions. Phase imbalances that occur when the transformer is idle cause both inductive and capacitive reactive energy distortions at medium voltage. Additionally, long distances between the meter and the transformer further increase capacitive effects, negatively impacting measurement accuracy.

In such cases, directly obtaining current information from XLPE cable-type current transformers on the medium-voltage side and using an SVC system are critical for achieving high-precision and stable power factor correction.

The MV Current-Referenced and SVC-Featured Power Factor Controller obtains current information from the measuring current transformers on the medium-voltage side or from the three newly installed XLPE cable-type measuring current transformers, and voltage information from the low-voltage side. The power of each phase is measured independently, taking into account the phase angle difference. As a result of this measurement, the power factor controller provides optimal solutions to the system on the low-voltage side by precisely utilizing both the existing stages and the SVC outputs.

1.2. Technical Features

Standard	:	TS EN 61869-2
Rated Operating Voltage (Un)	:	720 V
Rated Frequency	:	50 - 60 Hz
Rated Thermal Continuous Current	:	1.2 x In
Rated Thermal Current (Ith)	:	60 x In / 1 sec.
Rated Dynamic Current (Idyn)	:	2.5 x Ith / 1 period
Rated Power Frequency withstand Voltage	:	3 kV (50 Hz) / 1 min.
Degree of Protection	:	IP20
Instrument Security Factor	:	< 5
Ambient Temperature	:	-10 / +55 °C
Relative Humidity	:	Maximum %95
Accuracy Class	:	0,5 Cl
Burden	:	1,25-5 VA
Rated Primary Current	:	40A - 100A
Rated Secondary Current	:	1A-5 A

1.3. Technical Drawing

XLPE Cable Type Current Transformers

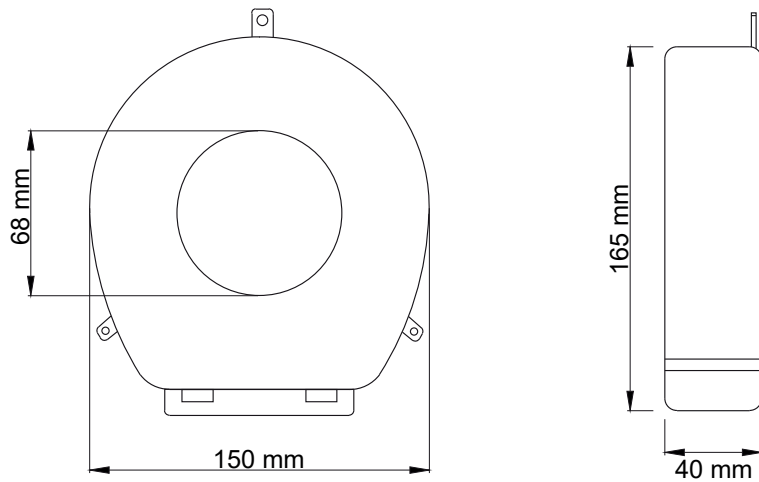

Warning: It is only used together with our MV-Referenced Power Factor Controllers. It is definitely not connected to MV busbars, it is connected to XLPE cables.

1.4. Connection Diagrams

1.4.1. Medium Voltage Reference System Connection Diagram Example

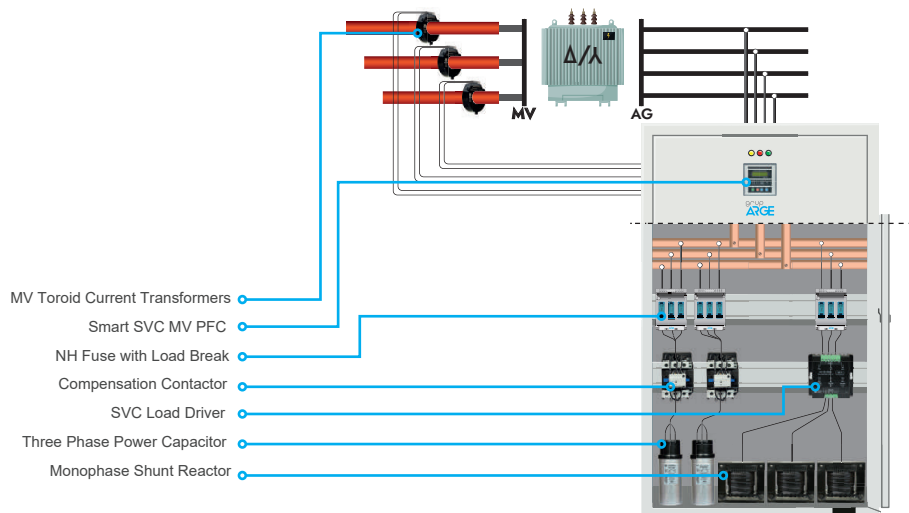

1.4.2. XLPE Cable Type Current Transformers Connection Diagram

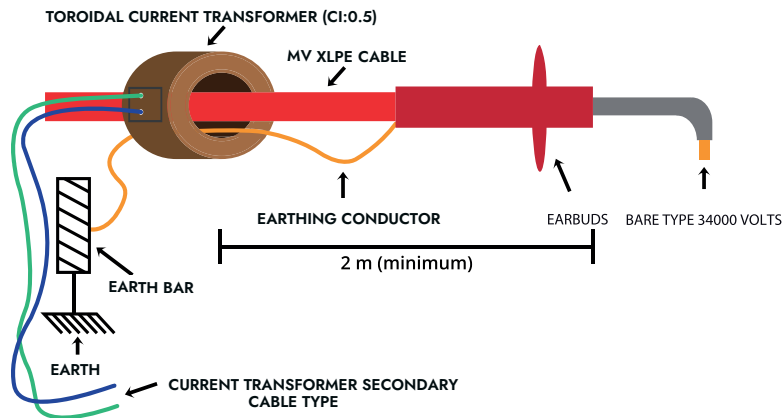

WARNING: The input phases of the driver and power factor controllers must be in the same order. In other words, L1 phase of the power factor controller and L1 phase of the driver, L2 phase of the power factor controller and L2 phase of the driver, L3 phase of the power factor controller and L3 phase of the driver must be the same. The driver must be controlled with TRG1-2-3

1.4.3. Connection Types Between Current Transformer and Earthing Cables

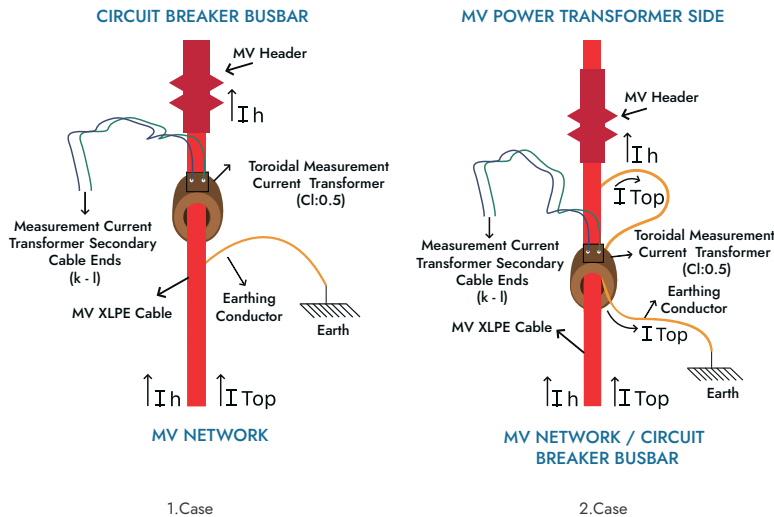

1. Case: Earthing Is Done On The Circuit Breaker Side
 2. Case: Earthing On The Power Transformer Side

1.4.4. XLPE Cable Type Current Transformer - Secondary Cable Cross-Sections (mm²)

The selection of current transformers that can be used according to the power capacities for SVC MV power factor controllers and cable cross-section - length dimensions are as in the table. (The cross-section values in the table are based on 34.5 kV voltage value).

Current Transformer	Transformer Power (kVA)	Distance Between Current Transformer and Power Factor Controller (m)				
		20	40	60	80	100
40/1	630	2,5	2,5	2,5	4	4
	1000	2,5	2,5	4	4	4
	1250	2,5	4	4	6	6
	1600	2,5	4	6	6	10
	2000	4	6	6	10	10
100/5	2500	4	6	10	10	10
	630	2,5	2,5	2,5	4	4
	1000	2,5	2,5	4	4	4
	1250	2,5	4	4	6	6
	1600	2,5	4	6	6	10
	2000	4	6	6	10	10
	2500	4	6	10	10	10