

Graphic LCD Display Smart SVC PFC User Manual



CONTENTS IN THIS MANUAL

SMART S18
SMART SOG1 - SMART SOG5
SMART SOG1D - SMART SOG5D

ADDRESS: Ikitelli OSB Mah. Cevre 14.
Blok Sok. Telas Blok Dis Kapi No: 1
Kat: 1-2 Basaksehir/Istanbul

Phone: +90 212 438 80 24
Fax: +90 212 438 80 25

info@gruparge.com

CONTENTS

PROPER USE AND SAFETY REQUIREMENTS.....	6
1. INTRODUCTION	7
1.1. Front Panel View.....	7
1.2. Functions of Key	8
1.3. Relationship of Key	9
1.4. Smart SVC PFC Features.....	10
1.5. Technical Drawing	11
1.5.1. Graphic LCD Display Smart SVC PFC Technical Drawing	11
1.6. Connection Diagrams.....	11
1.6.1. 18 Steps Smart S18 Connection Diagrams.....	11
1.6.2. 18 Steps Smart SOG1, SOG5 Connection Diagrams.....	12
1.6.3. 18 Steps Smart SOG1D, SOG5D Connection Diagrams.....	12
1.7. OG Toroidal Current Transformer.....	13
2. INSTALLATION.....	14
2.1. Installation and Activation.....	14
3. SETTINGS.....	18
3.1. Operating Screen.....	18
3.1.1. Instant Active/Reactive Powers and Percents.....	19
3.1.2. Achieved Inductive and Capacitive Ratios.....	19
3.1.3. Currents and Voltages	19
3.1.4. Instantaneous Frequency, Cos ϕ , and THD Values.....	20
3.1.5. Phase Sequence	20
3.1.6. Energy Consumption (Import) Values.. ..	20
3.1.7. Energy Production (Export) Values....	21
3.2. Main Menu and Sub-Menus of Smart SVC PFC.....	21
3.2.1. Step Powers.....	21
Displayed Step Powers and Meanings.....	22
Faulty Message.....	23
Cancellation Message.....	23
Step Error.....	24
3.2.2. Step Test.....	24
3.2.3. Transformer Test.....	26
The Warning Messages Indicating Connection Errors in Transformer Test.....	28

3.2.4. Step Control.....	30
3.2.5. Power Flow Chart.....	31
3.2.6. Advanced Settings.....	33
Current Transformer Ratio.....	33
Voltage Transformer Ratio	33
Inductive Limit.....	34
Capacitive Limit.....	34
LC Offset.....	34
Reactive Response Time.....	34
SVC Response Time.....	35
Normal Response Time.....	35
Capacitor Discharge Time.....	36
3.2.7. Expert Settings.....	36
Energy Integral Time.....	36
Ade Gain (Opm) Multiplier.....	37
Ade Hw Opm Multiplier.....	37
Modbus Address.....	37
Energy Reset.....	38
Deletion of Power Flow Chart.....	38
Step Transition Time.....	38
LC Max Opening (L1, L2, L3).....	38
Capacitive Delay Multiplier.....	39
Inductive Delay Multiplier.....	39
Off Set Step.....	39
Off Set Step Setting.....	40
Off Set Step Extra Information.....	40
Rapid Off Set On.....	40
Off Set Output.....	41
Off Set Enter.....	41
Off Set Reactive.....	41
Off Set Pin.....	41
Inductive Ratio Hysteresis.....	42
Capacitive Ratio Hysteresis.....	42
Response Resolution.....	42

Auto Step Test.....	43
LC Protection Multiplier.....	43
LC Protection Ratio.....	43
Gen Ind Limit.....	44
Gen Cap Limit.....	44
Second Zone Bas.....	44
Second Zone Multiplier.....	45
DYN Value.....	45
Export Energy.....	45
In Expr Comp Off.....	45
In Expr At Imprt.....	46
In Expr Comp Pass.....	46
Slayt On.....	46
Pwr Off Set Fac.....	46
AC Off Set Fac L1, L2, L3.....	47
In Off Set Fac L1, L2, L3.....	47
Cp Off Set Fac L1, L2, L3.....	47
Normal Effect.....	47
Ignore Mode.....	48
LC Force Fac.....	48
Auto Transformer Control.....	48
LC Add Fac.....	48
Oto Opm Mode.....	49
Sec Opm Mode.....	49
Adv Comp Mode.....	49
Prll Comp Mode.....	49
Selc Comp Mode.....	49
Ade Reset On.....	50
Back Light.....	50
Default Values.....	50
4. COMMON ERRORS.....	51
4.1. Common Errors and Solution Suggestions.....	51
4.2. Operating the Device in the Capacitive Zone	53

4.3. Operating the Device in the Inductive Zone.....	53
4.4. Formatting the Device (Reset).....	53
5. MODBUS.....	54
5.1. Communication Parameters	54
5.2. Differences from Standard MODBUS.....	54
5.3. Sample Query and Answer.....	54
5.4. Additional Explanations.....	54
Step Test Cancellation.....	55
Transformer Test.....	55
Transformer Test Cancellation.....	55
Step Values.....	55
Step Conditions.....	56
Step Usage.....	56
SVC Readings.....	56
Power Flow Graph.....	56
6. CAPACITOR TRANSFORMATION TABLE.....	70

PROPER USE AND SAFETY REQUIREMENTS



Cut all the power when connecting and disconnecting the device to a panel.



Do not clean the device with a solvent or similar material. Only use a dry cloth.



Please do not intervene to the device when a technical problem is encountered and get in contact with a technical service within the shortest time.



If the warnings are not taken into account, our company or the authorized dealer shall not be held responsible for the negative consequences.



Do not dispose in the trash, the device must be delivered to the collection centers (electronic device recycling centers). It should be recycled or disposed of without harming human health and environment.



The installation, assembly, activation and operation of the device should be done and used by only expert professionals and in accordance with safety regulations and instructions.

1. INTRODUCTION

1.1. Front Panel View

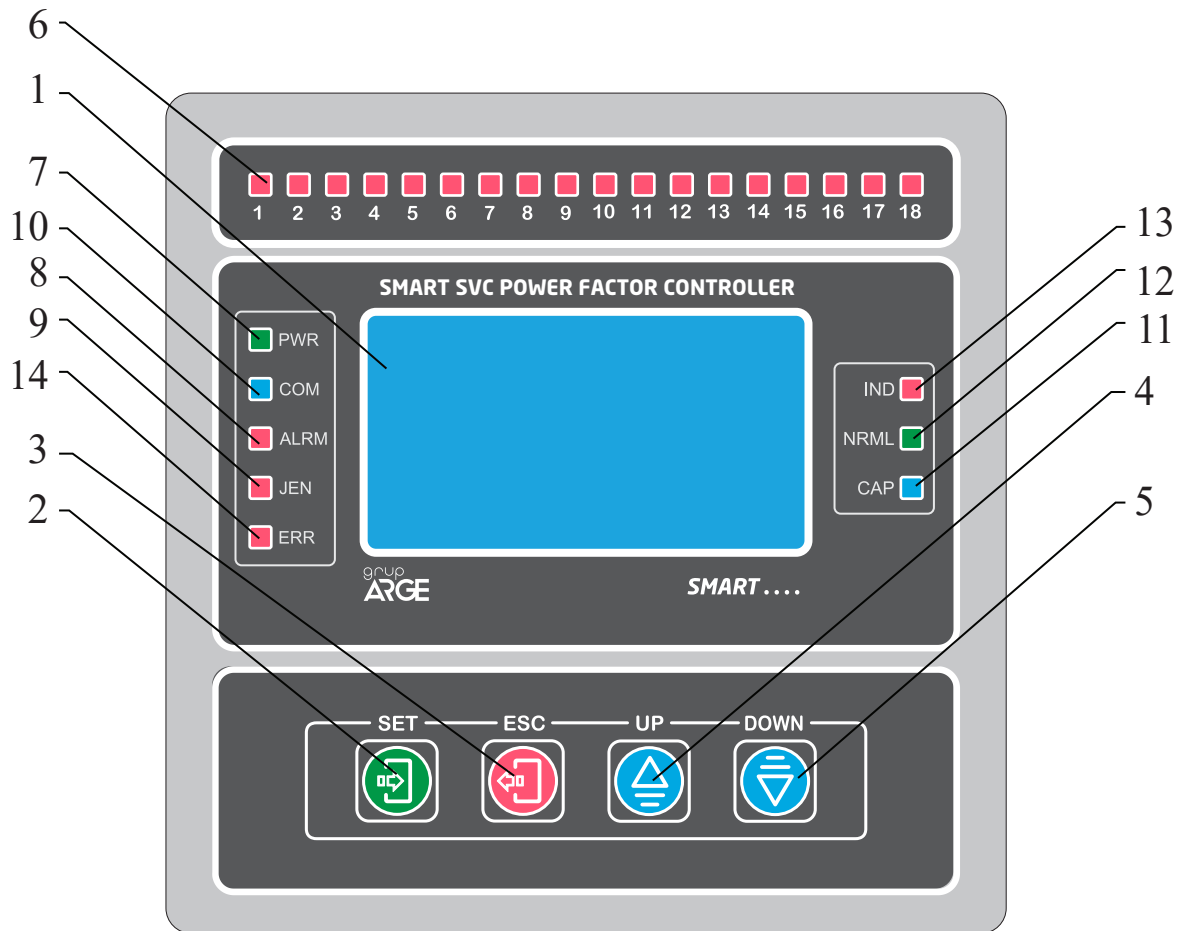

1- LCD Display: All powers, ratios, values, warnings and menu parameters are monitored on the display. Display lighting gets off automatically if no key is pressed for 2.5 minutes in operating mode. In this case it is sufficient for user to press a key to light the display again.

2- Program (SET) Key: The key to enter the menu, switch to a submenu and keep the settings.

3- Exit (ESC) Key: It enables to return to the previous process in the menu and exit from the menu.

4- Up Key: It enables to move upward in measurement and menu position.

5- Down Key: It enables to move downward in measurement and menu position.

6- Step LEDs: 18 pieces. The steps are stated on each LED. When the LED is on, it is understood the relevant LED is activated.

7- Energy (Power) LED: The LED indicating as PWR on Leksan. When there is energy in the device, this green coloured LED gets on. If it does not get on, there is a problem in the supply.

8- Alarm LED: It gets on when the system exceeds 15% cap and 20% end limits.

9- Gen LED : It gets on when the system is supplied from the generator.

10- Communication LED: This LED flashes during communication.

11- Capacitive LED: If total flowing capacitive reactive energy is above capacitive limit, this LED gets on.

12- Normal LED: If total flowing reactive energy from all phases is below Ind/Cap limits in PFCs, normal LED gets on.

13- Inductive LED: If total flowing inductive reactive energy is below inductive limit, this LED gets on.

14- Error LED: When thermal input is opened, in the errors of connection and step, no phase error, excessive inductive/capacitive errors, this LED gets on. If the LED gets on continuously, errors still exist. If error message is seen on the display and alarm LED is off, this means the errors occurred in the past and do not exist at the moment. In this case, the errors can be deleted by long press of ESC key.

1.2. Functions of Key



It is used to enter the menu and move to the next screen. Press this key for 3 sec to enter the menu. In order to store parameter which is set in the menu, press SET key and move to the next menu.



It enables to return to the previous process and exit from the menu.



It is used to change option and increase parameter value in the menu. Out of the menu, it ensures that the current display does not change for 1.5 minutes in operating time. The screens start to change automatically 1.5 minutes later. This key is used to enter step values manually during step test.



It is used to change option and decrease parameter value in the menu. Out of the menu, it is used to change screen from current to the next in operating time. The new screen stays unchanged for 1.5 minutes. The screens start to change automatically 1.5 minutes later. During the step test, this key is used to pass the tested step and proceed to the next step test.

1.3. Relationship of Key

- If you hold down up key in the step test, the manual login screen for that step comes up.
- If you hold down down key in the step test, the current step test is passed by via its previous value.
- If you hold down ESC key in any test, the test is cancelled.
- In manual step login, the value of each phase is entered separately. Transition between phases is done by pressing SET key. If you hold down ESC key during transition, the previous value of the phase is entered to another phase.
- **FORMAT:** Give energy to the device by holding down SET key and wait 5 sec in this position and press ESC key then leave firstly SET key and secondly ESC key; the format screen comes up.

If we cannot to use a step to report a load that the relay does not see: A load (capacitive effect of long MV cables or inductive loss of power transformer) that current transformer does not see can be defined to PFC via 'off set step'. For this process; firstly one of the steps is defined as 'off set', then apply 'step test' to this step and enter the convenient value is entered from manual login menu.

EXAMPLE: *The MV cable distance between electric meter and power transformer = 500m The capacitive effect of the cable = 25 kVAr (for 34.500 V voltage and 95 mm² XLPE cable)* In this case, even if the PFC makes $\cos\phi$ as 1, the meter will write capacitive due to the capacitive effect of the cable. Reactive difference between the meter and the PFC can be eliminated by making the necessary settings in the 'off set' step menu of SMART SVC PFC.

To activate a step manually;

If you want to activate a step manually, select the relevant step as 'off set' step. The PFC will activate that step manually after this process.

To take a step as a load to the system;

Select the relevant step as 'off set'. Then select the value of off set from 'off set' login screen as 0 or test 'off set' step by coming the step test and enter the value as 0 for each phase. After this process, the PFC will activate that step as a load.

If we want to report a value that the PFC does not see but the meter sees, we associate this value to a step and report to the relay. We name this step as 'off set' step. This can be any idle step. After we enter the number of this step in 'off set' login in the menu, we come to step test in the menu and test this step then we enter the value of the step for each phase as 'off set' value that the relay does not see in manual screen.

We can make 'off set' feature that is activated on any step active or passive via an external signal. The generator input of PFC can be used for this application by changing "off set" to "pin on" in the menu. When 220 Volt comes to generator input, 'off set' feature gets activated. Otherwise it gets passive.

EXAMPLE: Assume that in our system we have a cogeneration that gives capacitive load of approximately 200 kVAr and it outputs to MV line via a step-up transformer. Let our power factor correction be on LV side. We can use existing 'off set pin' feature to report to PFC that there is a 200 kVAr capacitive load, that the PFC does not see in the system when the cogeneration operates, and this load disappears when it is out of order. If a 220V output, that is taken when cogeneration is activated, is connected to this 'off set pin' input the 'off set' value (200 kVAr), that we entered to the PFC before, gets activated and the PFC compensates according to this. When cogeneration is passive, the PFC realizes this by pin login and makes 'off set' value, that is entered before, passive.

In the case of alarm when the screen flashes (when it passes to 20% end or 15%kap), the alarm LED gets on and the alarm contact outputs in the alarm output. When gen gets activated and 220 Volt entered to gen input, this LED gets on.

NOTE: The "Off set" step must be idle or you should make it ineffective by cutting the step energy. You can make it ineffective in the menu. (by making "off set out put" selection off).

NOTE: To get more information, you can call technical support numbers and get more detailed explanation.

1.4. Smart SVC PFC Features

- It is microprocessor-based.
- Eliminates the use of multiple single-phase steps (capacitors, contactors, fuses, etc.).
- Provides easy compensation for fast-changing loads.
- Eliminates the need for capacitors, contactors, fuses, etc.
- Fully addresses capacitive compensation that may arise from the use of compact fluorescent, LED lighting, electronic ballasts, uninterruptible power supplies, inverter-based air conditioners and coolers, etc.
- Since it is semiconductor-controlled, the life of the power steps is much longer than that of contactors.
- Compared to classic contactor-based compensation solutions, installation labor is reduced due to fewer steps.
- With a detection current of 3 mA, it can operate easily even in small-power facilities or large-power facilities with high current transformer ratios.
- Provides full compensation capability even with aged or faulty capacitors.
- The operation can be easily analyzed with the help of a power flow graph. The maximum and minimum capacitor/reactor sizes required for each phase and phase imbalances can be determined.
- It detects faults such as faulty steps, excessive inductive/capacitive, phase errors, connection errors, etc., and informs the user.
- Step values are continuously updated with automatic step testing.
- It automatically detects and corrects current transformer connection changes.
- It extends the compensation maintenance period while also reducing maintenance costs.
- When the SVC load divider and SVC reactors are not in use, it can also function as a classic relay. It can revert to SVC when needed.

1.5. Technical Drawing

1.5.1. Graphic LCD Display Smart SVC PFC Technical Drawing

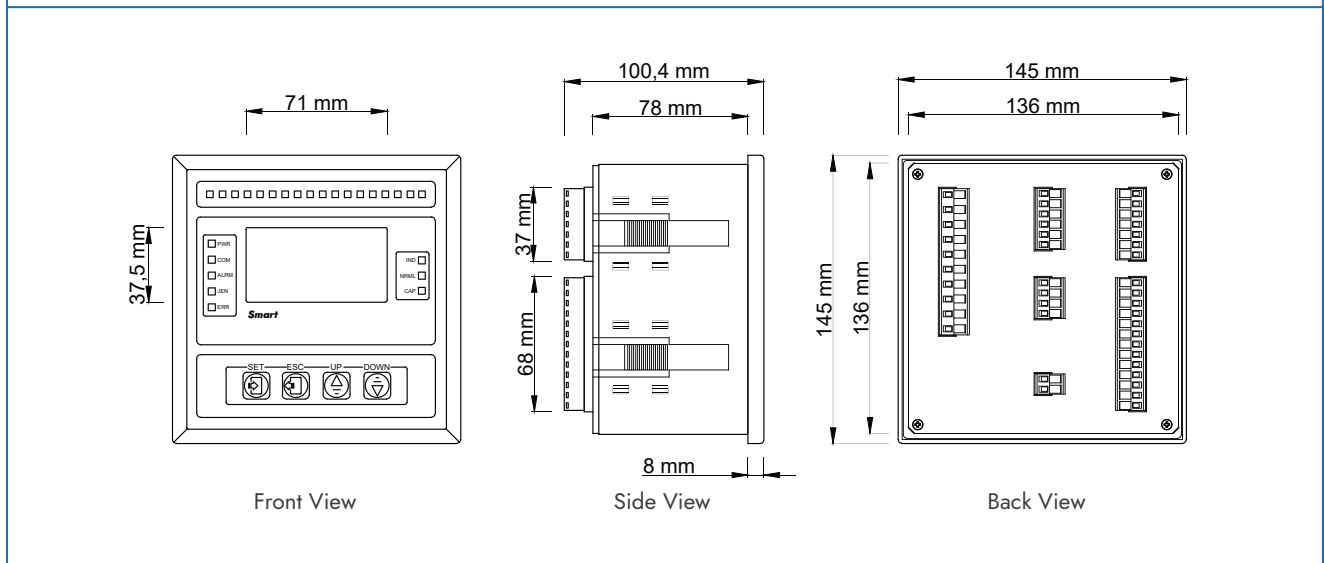

1.6. Connection Diagrams

1.6.1. 18 Steps Smart S18 Connection Diagrams

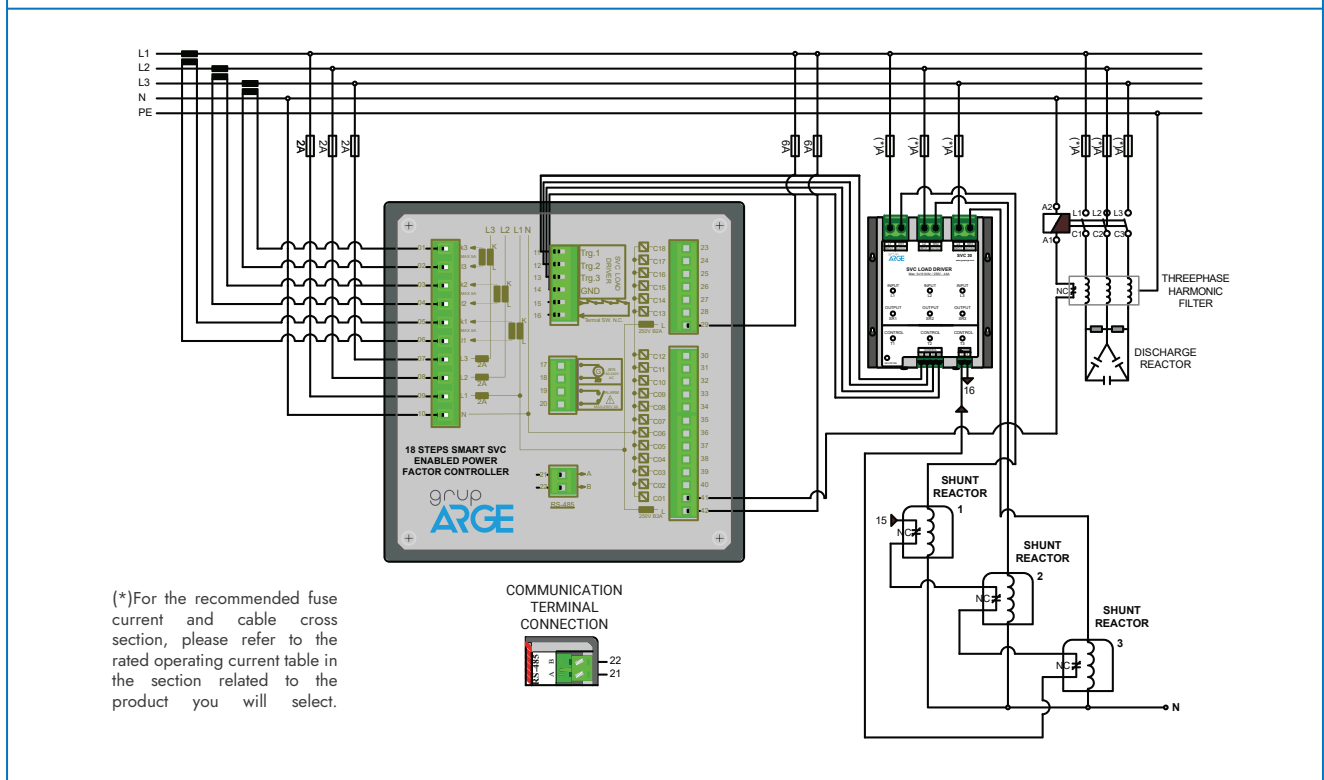

1.6.2. 18 Steps Smart SOG1, SOG5 Connection Diagrams

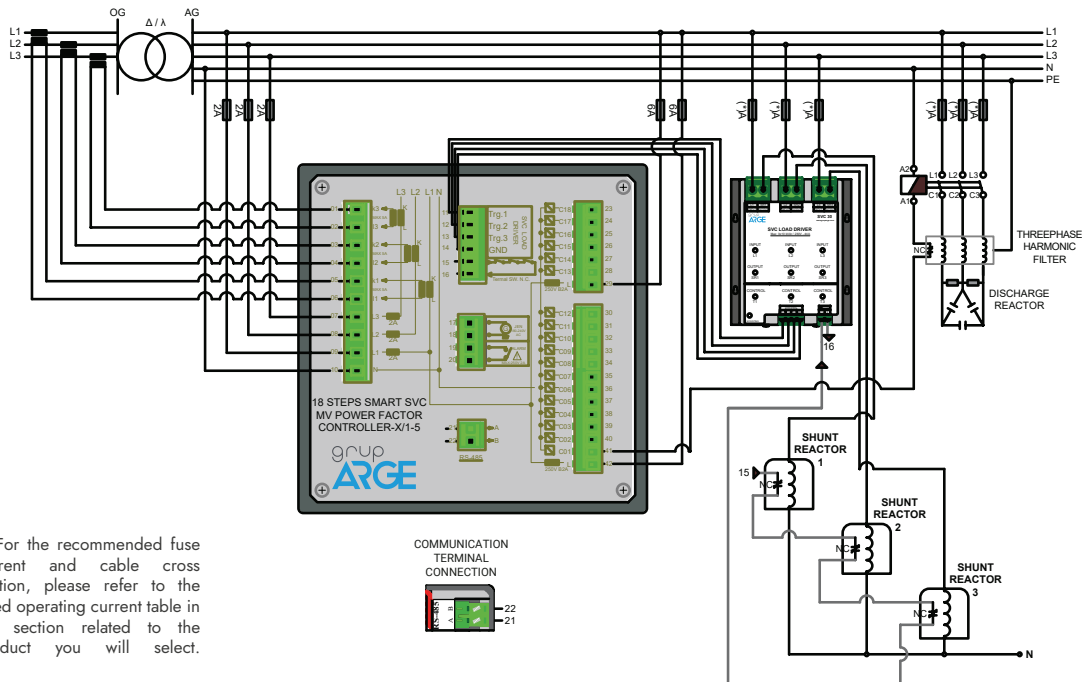

1.6.3. 18 Steps Smart SOG1D, SOG5D Connection Diagrams

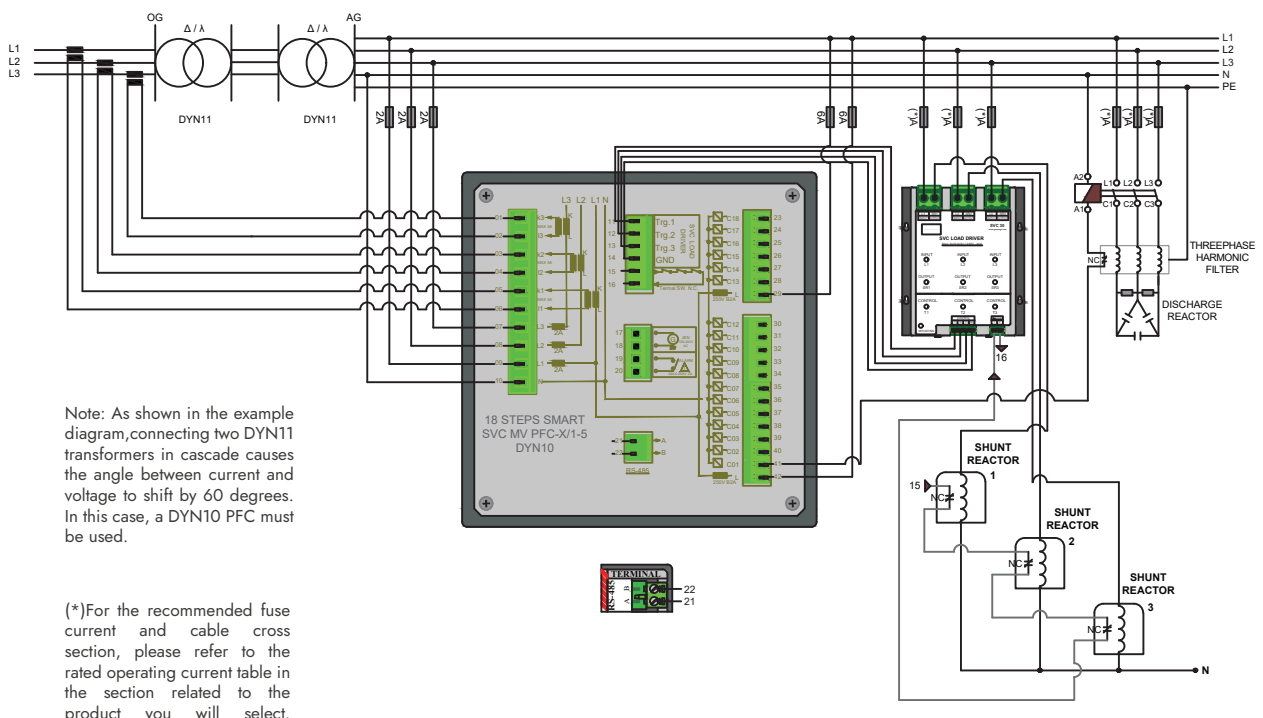

1.7. OG Toroidal Current Transformer

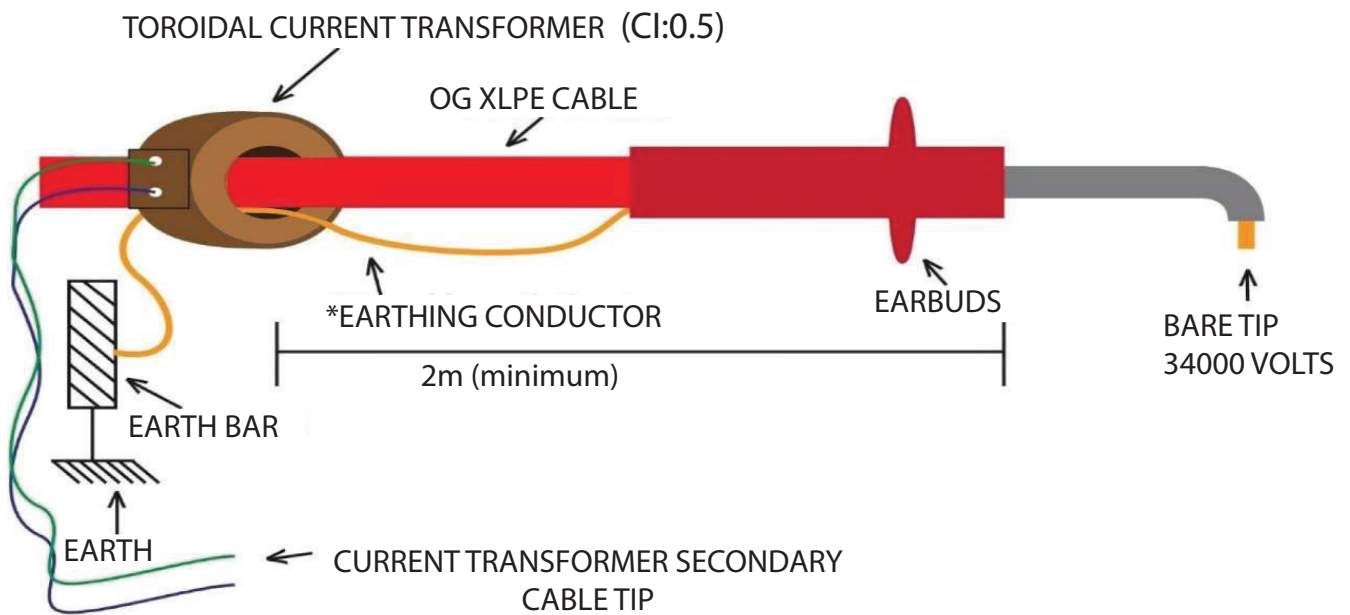

Warning: Input phases of driver and PFC must be definitely in the same order, so, L1 phase of PFC and L1 phase of driver, L2 phase of PFC and L2 phase of driver, L3 phase of PFC and L3 phase of driver must be same. The TRG1-2-3 order of driver must be done correctly.

2. INSTALLATION

2.1. Installation and Activation

After giving energy to the device, the message in figure 2.1 will be encountered. After this message flashes on the screen for 3 sec., this standby can be skipped by SET key. Then, current transformer ratio message (Figure 2.2) will be displayed on the screen.



Figure 2.1

After Figure 2.2 screen is displayed, the current transformer ratio of **SMART SVC PFC** can be set by up-down keys. After it is confirmed with **SET** key, **SMART SVC PFC** starts automatic transformer test.



Figure 2.2

In the transformer test, firstly the message (Figure 2.3) that the steps are being prepared is displayed.

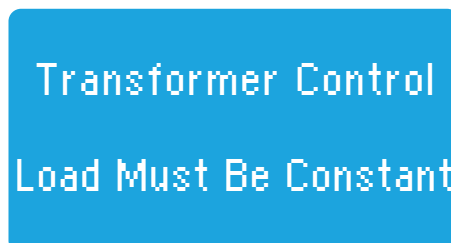
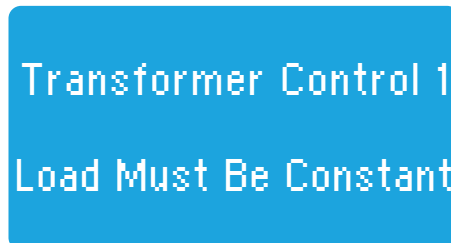

Figure 2.3

The point to consider in current transformer test is; voltage and current tips of each phase must be matched. L1 voltage that comes to relay and current tips in L1 busbar, L2 voltage and current tips in L2 busbar, L3 voltage and current tips in L3 busbar must be matched. In case of a different situation, it warns the PFC. SMART SVC PFC do transformer test for twice to eliminate the possibility of errors. The message below (Figure 2.4) will be displayed at the first transformer test.



Transformer Control 1
Load Must Be Constant

Figure 2.4

In the transformer test, if the current drawn by activated steps are insufficient, a message like in Figure 2.5 will be displayed.



Low Current!
L1 L2 L3

Figure 2.5

In this case **SMART SVC PFC** continues the test by increasing the activated steps.

Note: *Shunt reactors must be definitely connected to the last steps.*

If the connections are correct, a message like in Figure 2.6 will be displayed. Thus, the first test is completed and the device passes to second control.



L1 - L2 - L3 -
Recheck

Figure 2.6

Note: In the message below (Figure 2.6), “-” value displaying on the right side of L1, L2, L3 indicates current transformer connection directions. In the example “-” displaying next to “L2” indicates that the current transformer connection direction that is attached to the relevant phase is reverse. SMART SVC PFC realizes this situation and fix the reverse connection automatically. Please look at the section of ‘Transformer Test’ for details of the message that indicates connection errors.

The message in Figure 2.7 displays at the second transformer test and the test starts.

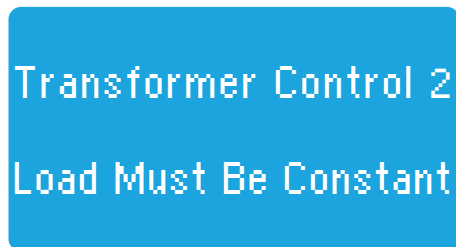

Transformer Control 2
Load Must Be Constant

Figure 2.7

After the repeated test, current directions are displayed on the device screen. (Figure 2.8).

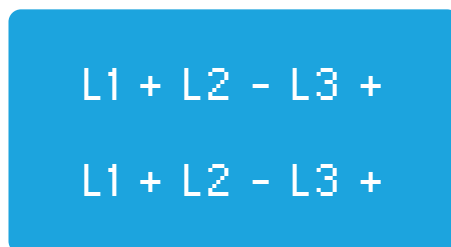

L1 + L2 - L3 +
L1 + L2 - L3 +

Figure 2.8

Transformer test is completed. (Figure 2.9).

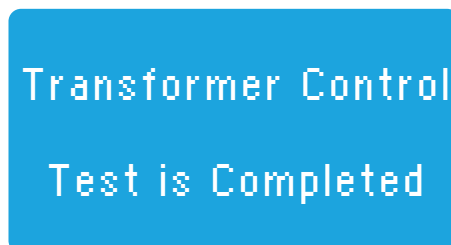

Transformer Control
Test is Completed

Figure 2.9

After completing the transformer test, the device starts step test automatically by receiving the following message. (Figure 2.10)

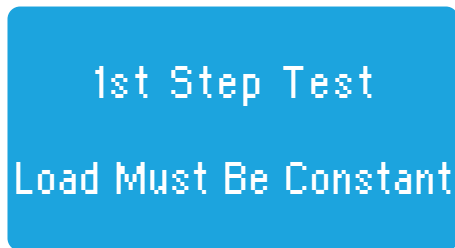

```
1st Step Test
Load Must Be Constant
```

Figure 2.10

The steps are measured automatically starting from first step and value of the step is recorded in SMART SCV PFC store. During measurement, the message below Figure 2.11 is displayed respectively for each step. In the first row of this message indicates which step is tested and in the second row the type and state information of the completed step (single phase, two phase, three phase, cancelled) are displayed.

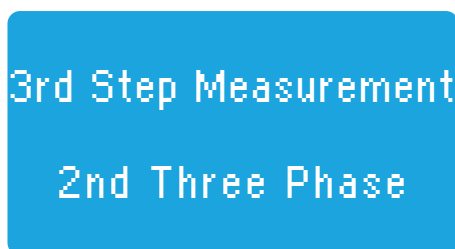

```
3rd Step Measurement
2nd Three Phase
```

Figure 2.11

If there is a load change during the test, the message in Figure 2.12 is displayed and the step test is repeated.

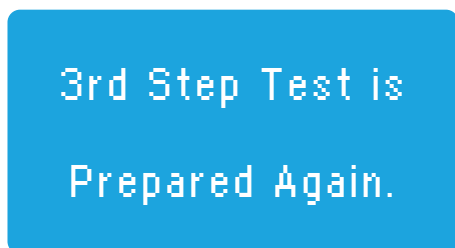

```
3rd Step Test is
Prepared Again.
```

Figure 2.12

While the step tests in progress, user can end the process by **ESC** key. After all the step measurements are done, the message in Figure 2.13 is displayed and the step test is completed.



Figure 2.13

After the steps above are completed, the installation of **SMART SVC PFC** is completed and the power factor correction starts to be controlled by **SMART SVC PFC**.

Note: *It would be useful for whole power factor correction system to control the values and states of capacitors, shunt reactors and contactors connected to the steps from ‘Step Power’ menu of Smart SVC PFC.*

3. SETTINGS

3.1. Operating Screen

After the installation of **SMART SVC PFC**, important parameters are displayed on the information screen. The device passes automatically from an information screen to another in 6-7 seconds. The values on the screen are updated in every 600 ms. and gives current information to the user. The **UP** and **DOWN** keys are used to move quickly between these information screens. In the screen displayed after pressing **UP** and **DOWN** key, the values are updated in every 600 ms and stand still for almost 1.5 minutes. After this, the screens are changed automatically 1.5 minutes later. Figure 3.1 shows a sample of the operating screen.

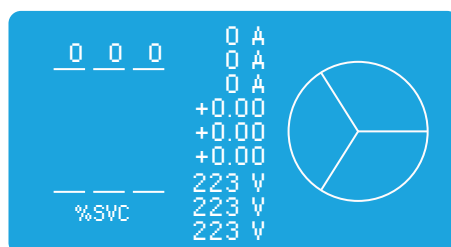

Figure 3.1

3.1.1. Instant Active/Reactive Powers and Percents

The following screen (Figure 3.2) displays the active power flowing through the L1, L2, and L3 phases on the left side of the screen, the reactive power on the right side, and their instantaneous percentage ratios at the bottom of the screen. The “+” sign indicates **"consumption"** for active power and **"inductive power"** for reactive power, while the “T” sign indicates **"production"** for active power and **"capacitive power"** for reactive power.

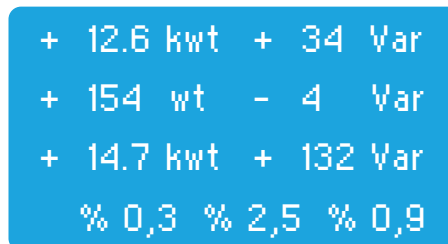

Figure 3.2

3.1.2. Achieved Inductive and Capacitive Ratios

In this screen (Figure 3.3), you can see in high resolution last 24 hours achieved inductive/active and capacitive/active percents. In this way, you do not need to check the index from the meter. If **ESC** key is pressed more than 3 seconds in operating screen, the ratios that **SMART SVC PFC** calculated are reset and starts to be calculated again.

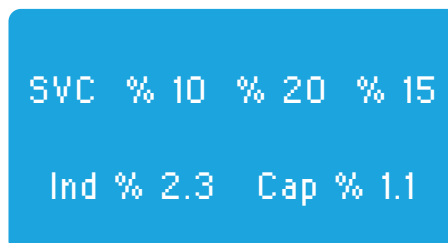

Figure 3.3

3.1.3. Currents and Voltages

The instant current and voltage values belonging to L1, L2 and L3 phases can be displayed on the operating screen of **SMART SVC PFC**. The current and voltage values belonging to L1, L2 and L3 phases are displayed like in (Figure 3.4)

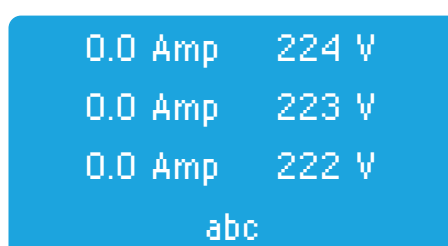

Figure 3.4

3.1.4. Instantaneous Frequency, Cos ϕ , and THD Values

This screen (Figure 3.5) displays the instantaneous Frequency, Cos ϕ , and THD values for each phase. Negative (-) values on the screen indicate that Cos ϕ is in the capacitive region, while positive (+) values indicate that it is in the inductive region.

f	Cos	Thd
50.0	1.00	1
50.0	1.00	1
50.0	1.00	1

Figure 3.5

3.1.5. Phase Sequence

The phase sequence indicator is like below

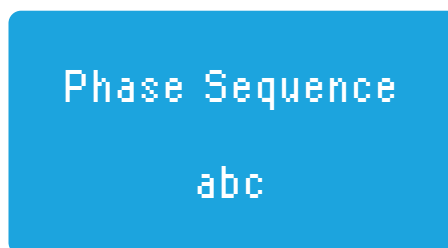

Figure 3.6

3.1.6. Energy Consumption (Import) Values

On the Smart SVC PFC's operating screen, the system's Import (Consumption) direction Active, Inductive and Capacitive energy values are displayed on the screen as shown in (Figure 3.7).

+ Energy	
AC	512037Wh
Ind	59706Vrh
Cap	54706Vrh

Figure 3.7

3.1.7. Energy Production (Export) Values

On the Smart SVC PFC's operating screen, the Active, Inductive and Capacitive energy values transferred to the grid by the system are displayed on the screen as shown in (Figure 3.8).

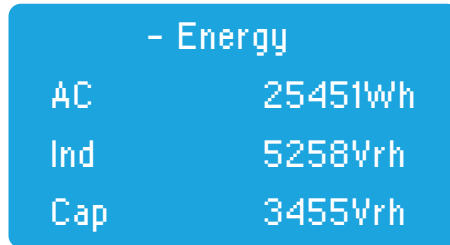

- Energy	
AC	25451Wh
Ind	5258Vrh
Cap	3455Vrh

Figure 3.8

3.2. Main Menu and Sub-Menus of Smart SVC PFC

To enter the menu when the device is in on operating mode, press **SET** key for 3 sec. To stroll in main menu, **SET** key is used. After reaching to the desired menu option, the selection can be made with **UP / DOWN** keys. The selection is confirmed by pressing **SET** key again or reaches to sub-menus if they exist. If desired, **ESC** key is used for existing from menu. If user stays in the menu longer than 1.5 minutes, device exists from the menu automatically and returns to operating mode

3.2.1. Step Powers

It is the first menu option that is entered by pressing **SET** key in operating mode. A message like below (Figure 3.9) is encountered. It is stated that the values of step powers per phase are displayed separately.

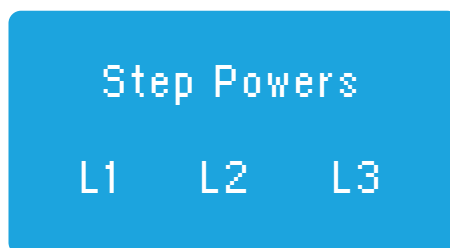

Step Powers		
L1	L2	L3

Figure 3.9

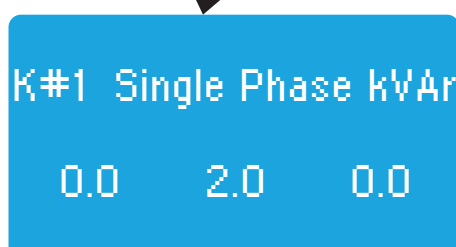

K#1 Single Phase kVAr		
0.0	2.0	0.0

Figure 3.10

In this menu, the type and states of the steps connected to the device can be seen. When the message above is displayed on the screen, you can switch between the steps with **UP/DOWN** keys. In SVC featured PFCs, information about reactors is given in the last 3 steps. The value of the reactors connected to step is stated as "-".

Displayed Step Powers and Meanings

In the chart below (Figure 3.11), the message example, that is displayed when entering step powers menu, is indicated and explained.

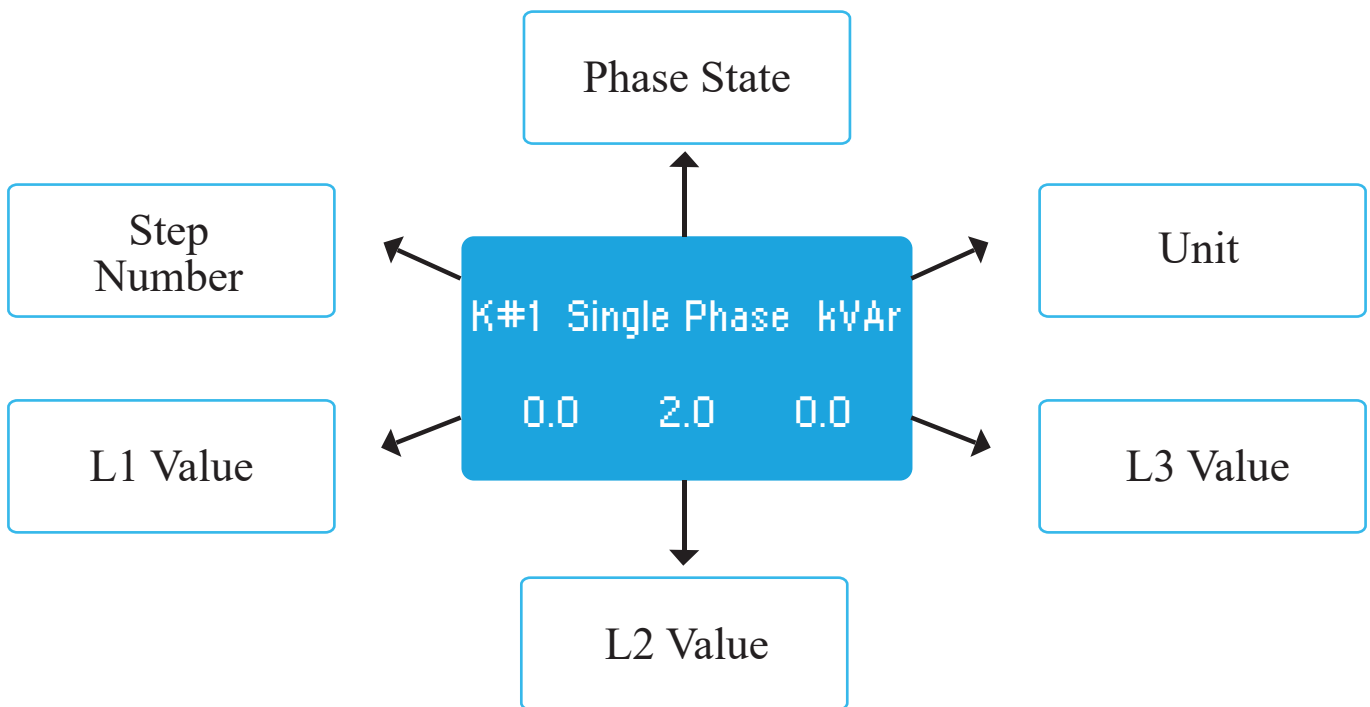

Figure 3.11

The following screens (Figure 3.12, Figure 3.13, Figure 3.14) are examples showing the steps with three-phase, two-phase, and single-phase capacitors.

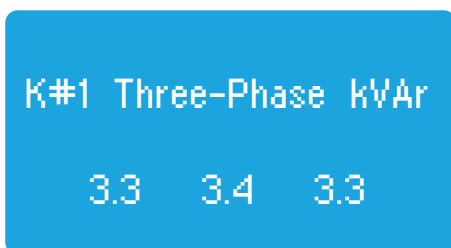

Figure 3.12

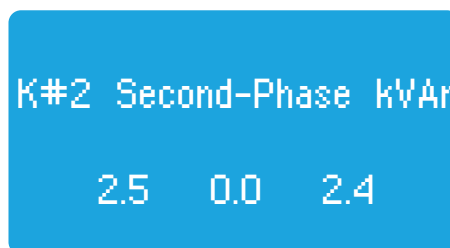
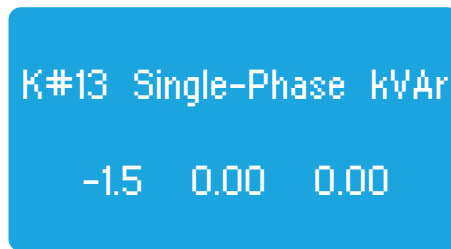

Figure 3.13



Figure 3.14

The shunt reactors that inductive load driver controls are displayed in steps 13, 14, and 15. (19, 20, 21 in 18-Step PFCs) For example, 13th step is displayed like below (Figure 3.15).



```
K#13 Single-Phase kVAr
-1.5  0.00  0.00
```

Figure 3.15

Faulty Message

If there is 15% value difference between phases in a three phase capacitor that its value changed, user is informed with a message in the section of phase mode saying 'Faulty'. In this case, it is displayed like the following. (Figure 3.16).



```
K#4 Faulty kVAr
3.4   2.2   3.4
```

Figure 3.16

Cancellation Message

SMART SVC PFC automatically cancels the steps that any capacitor or reactor does not connect a screen like following (Figure 3.17) informs user that this step is cancelled.

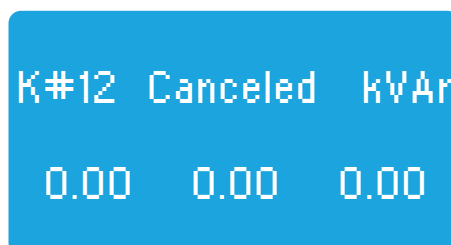

```
K#12 Canceled kVAr
0.00  0.00  0.00
```

Figure 3.17

Step Error

SMART SVC PFC informs user about an error that it discovers in any step by flashing error LED in operating mode and by sending step error message. In addition, in step menu, in which step the error occurs is displayed with “!” instead of “#” like in the screen below (Figure 3.18). For a healthy power factor correction, the problem of this step must be fixed by the user.

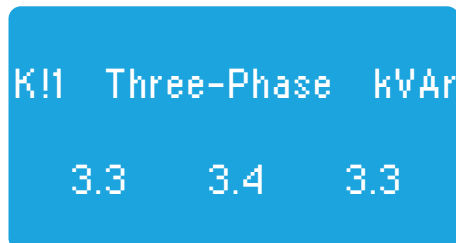

Figure 3.18

3.2.2. Step Test

The Step Test menu is displayed after the Step Powers menu. (Figure 3.19).

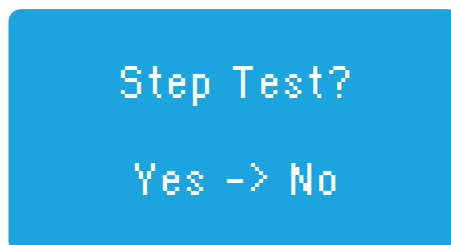

Figure 3.19

When you want to do a step test, you should bring the arrow to “**Yes**” with **UP / DOWN** keys and confirm it with **SET** key. A sub-menu like in below will display. (Figure 3.20).

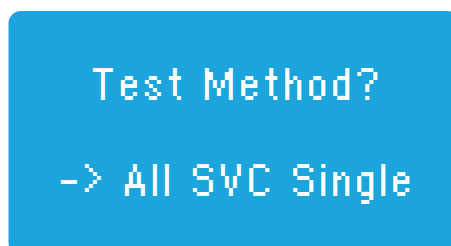

Figure 3.20

A test for all steps (1-18) with “All” and for shunt reactor steps that the driver controls (13-14-15 for 12-Step PFCs, 19-20-21 for 18-Step PFCs) with “SVC” is started. If “Single” option is selected, the wanted step is selected with UP / DOWN from sub-menu below (Figure 3.21) and step test is started.



Figure 3.21

Press SET key to start step test. Step test starts after informing user with the screen below (Figure 3.22).



Figure 3.22

NOT: In order for step test to be completed in a short time, the loads in the system must be constant if possible. The test can be done under a load but the test time may extend.

In step test, starting from the selected step, the steps are automatically measured and step values are saved to the storage of SMART SVC PFC. During measurement, the message in the (Figure 3.23) displays on the screen for each step. In the first row of this message which step is tested, in the second row the type and state information of the completed step is displayed. If a load change happens in the system during the test, the step test is repeated after the message in (Figure 3.24) is displayed

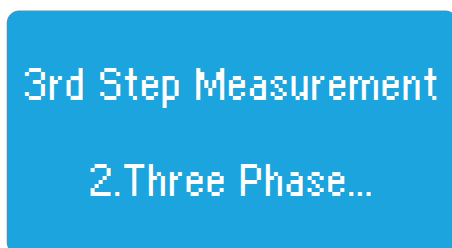

Figure 3.23

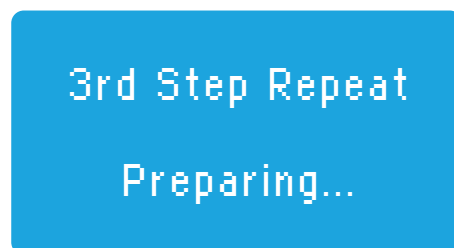
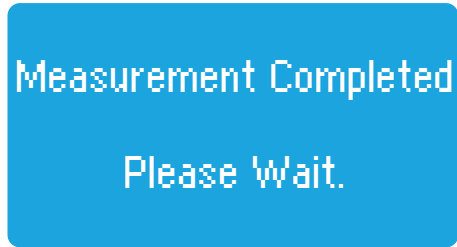

Figure 3.24

The step test is completed with the message below (Figure 3.25) after all the step measurements are done.



Measurement Completed
Please Wait.

Figure 3.25

NOTE: The user can cancel the test by holding down **ESC** key during the step test. In this case, old values of completed steps are preserved. During the step test, **DOWN** key is used to pass the tested step and proceed to the next. To enter step values manually, **UP** key is used.

3.2.3. Transformer Test

After Step Test menu, Transformer Test menu is displayed on the screen (Figure 3.26).

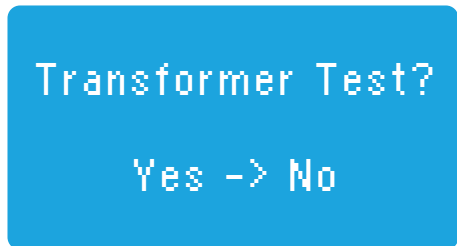

Transformer Test?
Yes -> No

Figure 3.26

When you want to do a transformer test, you should bring the arrow to “**Yes**” with **UP / DOWN** keys and confirm it with **SET** key, then the transformer test starts.

The point to regard in current transformer rate; voltage tips and current tips of each phase must be matched. Thus; L1 voltage tip and k1-11 current tip, L2 voltage tip and k2-12 current tip, L3 voltage tip and k3-13 current tip must be matched to back input of Smart SVC PFC. Buzzing sound of current transformers indicates that there is a problem in matching or connection.

In the transformer test, SMART SVC PFC waits for preparation of steps by receiving the message below (Figure 3.27)

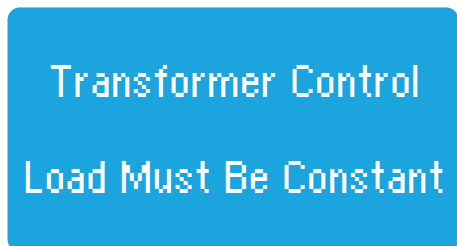

Transformer Control
Load Must Be Constant

Figure 3.27

With the message in (Figure 3.28), the device starts current transformer test by activating the first three steps.

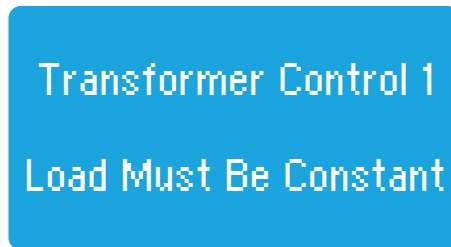

Transformer Control 1
Load Must Be Constant

Figure 3.28

If the connections are correct, the information about completion of the first test is given to the user after the message in (Figure 3.29).

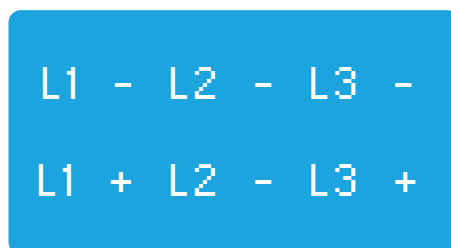

L1 - L2 - L3 -
L1 + L2 - L3 +

Figure 3.29

NOTE: “+” and “-” values on the rightside of L1, L2, L3 states current transformer connection directions. In the example, “-” displaying next to “L2” indicated the current transformer direction that is attached to the relevant phase is reversed. SMART SVC PFC realizes this situation and fix the reverse connection automatically.

NOTE: If the current drawn by activated steps is insufficient, Smart PFC increases the number of activated steps and continues the test.

NOTE: In order for SMART SVC PFC to complete current transformer test in a short time, it is advised to place three-phase capacitors to the first steps from large to small. Connecting two-phase, single-phase capacitors and constant shunt reactors to the next steps enables transformer test to be completed in a short time. It is not compulsory to carry out this advice. Even though steps connections are not done like above, Smart relay will complete the test and start to operate correctly. In addition to this, it is recommended that the current transformer used in the system have a class of 0.5 for measurement accuracy.

After the first completed transformer test, the following message (Figure 3.30) will display on the screen and the current transformer test repeats for control.



Transformer Control 2
Load Must Be Constant

Figure 3.30

After the repeated current transformer test, the message in (Figure 3.31) informs the user about current transformer directions and the process completed by receiving the message in (Figure 3.32)

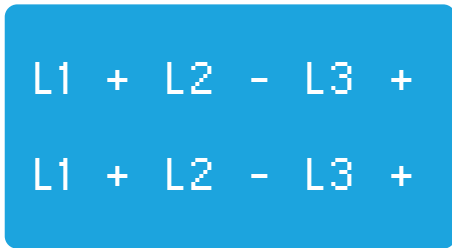

Figure 3.31



Figure 3.32

NOTE: If SMART SVC PFC realizes any difference in current transformer connection with the previous ones, it automatically makes the step test after the current transformer test.

If SMART SVC PFC detects a change in any current transformer direction, it automatically makes a step test. If the user wants to end current transformer test due to any reason, the user must press ESC key until the test is cancelled. The cancellation of the current transformer test is specialization-required subject. In the case of cancellation of this test, the user must consider connection directions and input/output. It is not recommended to cancel the current transformer test.

The Warning Messages Indicating Connection Errors in Transformer Test



Figure 3.33

Possible causes and solutions according to (Figure 3.33):

- Monophase capacitors may be connected to the first steps. The user must wait for PFC to draw three-phase capacitors.

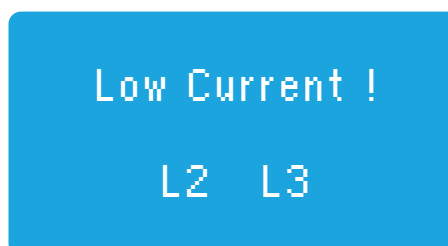

Figure 3.34

Possible causes and solutions according to (Figure 3.34):

- There may be a problem in current transformer or connections of L2 and L3.
- The current transformer of L2 and L3 phases are connected to wrong point.
- The k-1 tips of k2-12 and k3-13 terminals current transformers, which are attached for measuring L2 and L3 phases, may be mixed with each other. In this case, the k2-13 tips must be relocated in the device input and the test must be repeated.
- There may be connection errors. The user must follow the connections and fix the errors.
- There is not sufficient current in L2 and L3 phases during the transformer test.

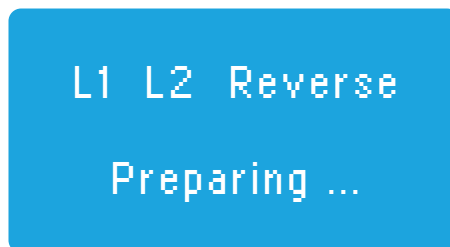

Figure 3.35

Possible causes and solutions according to (Figure 3.35):

- The current transformer tips of L1 phase to k2-12 inputs, the current transformer tips of L2 phase are connected incorrectly to k1-11 inputs. In this case, the voltage tips of L1 and L2 phases must be interchanged.

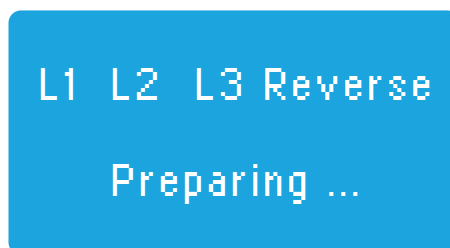

Figure 3.36

Possible causes and solutions according to (Figure 3.36):

- The voltage tips and current transformer tips of phases are not matched. In this case, the voltage tips of any two phases must be interchanged and the test must be repeated. According to the new test result, the matching error in other phases must be fixed.

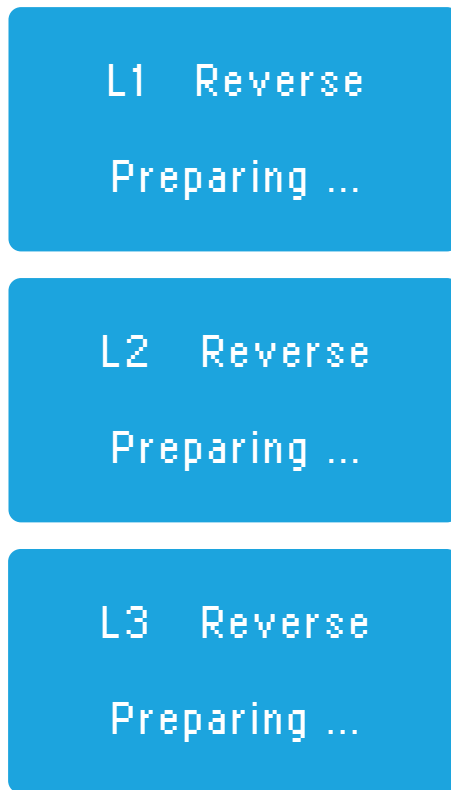

Figure 3.37

Possible causes and solutions according to (Figure 3.37):

- This warning is not expected normally. Thus, unexpected powers are measured when we draw the step. It means that the PFC cannot detect transformer directions from these pointless powers. Generally, if steps that are activated for transformer test are left in two phases or there are powers in and out, these unexpected values occur. In this case, taking large powerful capacitors in the first steps and making the current, drawn by system, stable ease the transformer test.

3.2.4. Step Control

The Step Control menu comes after the Transformer Test (Figure 3.38) menu.

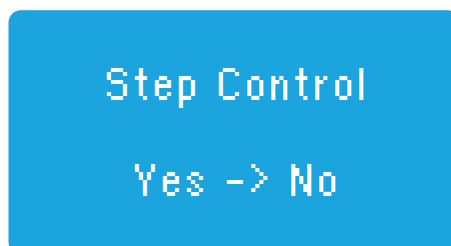

Figure 3.38

When you want to enter the step control menu, you should bring the arrow to “Yes” with UP / DOWN keys and confirm it with SET key, and then you can control steps via the screen below (Figure 3.39).

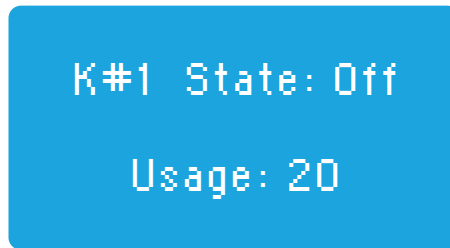

Figure 3.39

NOTE: In the figure above, it is indicated with “Off” that the state of the first step is deactivated and it is indicated to the user that this step is activated for “20” times since the last operating of SMART SVC PFC.

If SET key is pressed in the screen above of step control menu (Figure 3.40), the state of the selected step can be changed manually.

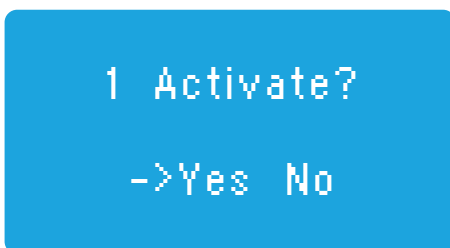

Figure 3.40

If the step is deactivated, the user is directed with the screen in Figure 3.40 when pressed SET key.

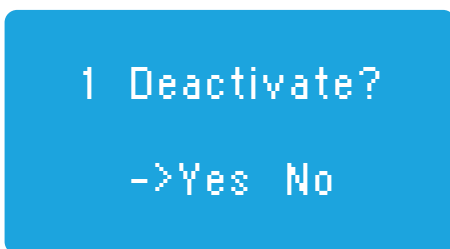

Figure 3.41

If the step is activated, the user is directed with the screen in Figure 3.41 when pressed SET key

NOTE: The user can control manually the relevant step via SMART SVC PFC. In this way, it can test the contactor and the capacitor. If wanted, you can exist from this menu with ESC key. When SMART SVC PFC existing from this menu, the state of the steps returns to the old state.

3.2.5. Power Flow Chart

The feature of SMART SVC PFC that brings out power profile of the system and gives valuable information to the user as long as existing in synthesis of power factor correction is named as “Power Flow Chart”. When doing power factor correction process, SMART SVC PFC calculates the data in power flow chart as if there is no power factor correction in the system and saves reactive powers that the system draws. It states these powers and how much time flowed in total with their percentages.

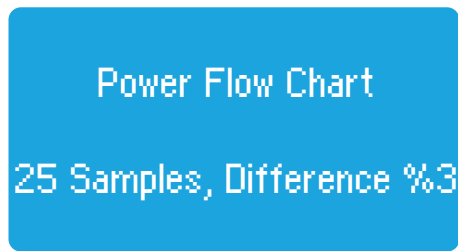

Figure 3.42

The power flow chart firstly gives information to the user with the screen above. In the screen above (Figure 3.42), it is stated that there are 25 samples and the difference between the samples is 3%. This message disappears after 2-3 seconds.

SMART SVC PFC lines up power samples from the longest-term example to the shortestterm sample. The user can stroll between the next / previous samples with **UP / DOWN** keys. The percentage in there indicates the ratio of a sample time to the time of all samples. In other words, it gives percentage of power sample on periodic basis. This percentage informs the user about how much the relevant power sample must be regarded when creating the power factor correction system. The bigger the percentage is the more important power sample for power factor correction system.

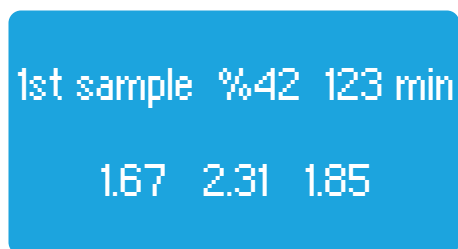

Figure 3.43

The positive values in the second row of power sample screen (Figure 3.43) in the above indicate inductive powers that the system draws and negative powers indicate capacitive powers. In the first row of the screen above; the information is given about that the first sample is drawn by system for 123 minutes in total and the percentage in time of this sample is 42%. In the second row, it is seen that 1.67 kVAR inductive from L1 phase, 2.31 kVAR inductive from L2 phase and 1.85 kVAR inductive powers are drawn from L3 phase. This power profile information indicates that the user needs to add 7.5 kVAR three-phase capacitor to the step in a SVC set of 1.5 kVAR. If all the large percent samples in the power flow chart are regarded, the number and power of capacitor and shunt reactors to be attached to steps in the power factor correction system can be easily determined.

3.2.6. Advanced Settings

The response of SMART SVC PFC to the system can be set by some parameters. These parameters are presented as a whole to the user in the sub-menu of “Advanced Settings” (Figure 3.44).

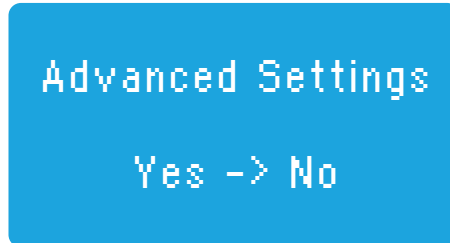

Figure 3.44

Bring the arrow to “Yes” with **UP / DOWN** keys and enter the advanced settings with **SET** key.

Current Transformer Ratio

The Current Transformer Ratio message screen is like in (Figure 3.45).



Figure 3.45

The Current Transformer ratio can be set with **UP / DOWN** keys in this menu. When the current transformer ratio is changed, SMART SVC PFC automatically makes the current transformer test and renews the step test. If the current transformer ratio is entered incorrectly by the user and the active and reactive power values displaying on the screen of the device are seen as erroneous, it does not affect SMART SVC PFC power factor correction process.

NOTE: The current transformer ratio can be set between 5/5 and 10000/5. When entering current transformer ratio in X1A PFC, the primary value must be entered like in the tag but secondary value must be entered as 5.

Voltage Transformer Ratio

The voltage transformer ratio message screen is like in Figure 3.44. The values on the tag of power transformer are regarded. The first statement states the phase-phase primary input of the transformer (34200) and the second statement states the secondary phase-phase output (380).



Figure 3.46

Inductive Limit

The inductive limit menu enables to set necessary inductive limit for the system to operate correctly. If the set limit is exceeded, the device gets activated and the values are automatically lowered under this limit. If the inductive limit is set to 1%, the relay focuses on capacitive ratio when calculating reactive ratio.

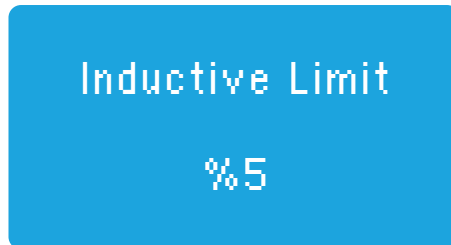

Figure 3.47

Capacitive Limit

The capacitive limit menu enables to set necessary capacitive limit for the system to operate correctly. If the set limit is exceeded, the device gets activated and the values are automatically lowered under this limit.



Figure 3.48

LC Offset

It exists in all the 18-step relays. The message screen is seen in (Figure 3.49). *It is used to synchronize the meter with the PFC in very low-load systems.*

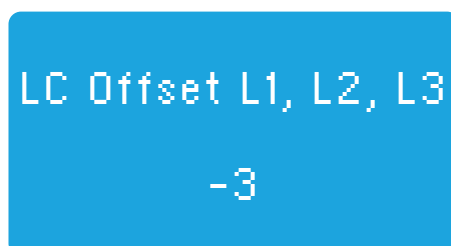

Figure 3.49

Reactive Response Time

The reactive response time message screen is like in (Figure 3.50).



Figure 3.50

This value can be set with **UP / DOWN** keys. The value is confirmed with **SET** key and proceeds to the next menu. Reactive response time is the parameter that determines how much time later the reactive ratios, that SMART SVC PFC calculated, can response after limit value is exceeded. As this time shortens, the response time of SMART SVC PFC quickens. If there are not loads that change very quickly, increasing this time can be preferred.

***NOTE:** The factory output time for this parameter is 4 sec.*

***NOTE:** The reactive response time can be set between 0 and 20 sec.*

SVC Response Time

The SVC response time message screen is like in Figure 3.51. This menu exists only in the PFCs with SVC system.

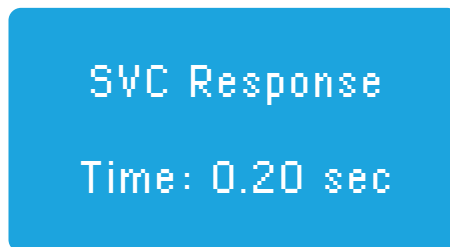

Figure 3.51

Normal Response Time

The normal response time message screen is like in Figure 3.52. This menu exists only in PFCs with SVC system.

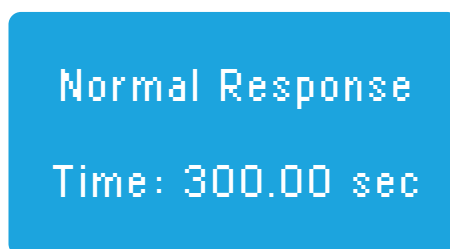

Figure 3.52

This value can be set with **UP / DOWN** keys. The value is confirmed with **SET** key and proceeds to the next menu. The normal response time is the parameter that determines how much time later the new found solution can be applied to the system when the reactive ratios that **SMART SVC PFC** calculated are under the limit value. As this time shortens, **SMART SCV PFC** will get more dynamic. It is not recommended to shorten this time unless it is necessary!

***NOTE:** The factory output time for this parameter is 300 sec.*

Capacitor Discharge Time

The capacitor discharge time message screen is like in (Figure 3.53).

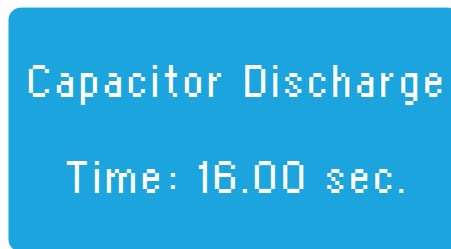

Figure 3.53

This value can be set with **UP/ DOWN** keys. The setting is confirmed with **SET** key and process to next menu. It is the time that determines how much time the device will wait after deactivating a capacitor. The manufacturers of capacitor do not recommend shortening this time!

NOTE: The factory output value for this parameter is 16 sec

NOTE: The capacitor discharge time can be set between 0 and 600 sec.

3.2.7. Expert Settings

The response of SMART SVC PFC to the system can be set via some parameters. These parameters are presented to the user in 'Expert Settings' sub-menu (Figure3.54).

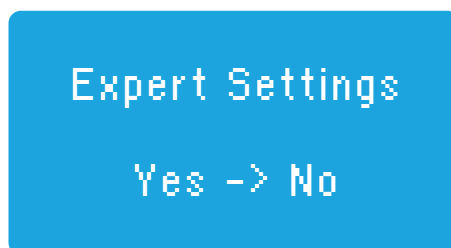

Figure 3.54

Energy Integral Time

The integral of power to a particular time gives energy as seen in the formula $W = \int_0^t$. The Energy Integral Time Menu is used to determine "t" or time, in this formula. The energy generated within the specified time band is divided by the specified duration to obtain the average power. It is used for precise measurements at low currents.

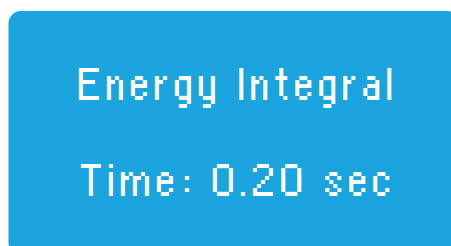

Figure 3.55

Ade Gain (Opm) Multiplier

It indicates current multiplier coefficient for a high resolution measurement (accurate) in very low currents. The current is given to measurement channel by strengthening it up to opm multiplier. In this way, the high resolution is obtained.



Figure 3.56

NOTE: Ade Opamp (Gain) Multiplier can be set as 1, 2 and 4.

Ade Hw Opm Multiplier

It is the state when Ade Gain (Opm) Multiplier menu make a step test. This means that the current is increased by the multiplier in the step test at very high conversion ratios.

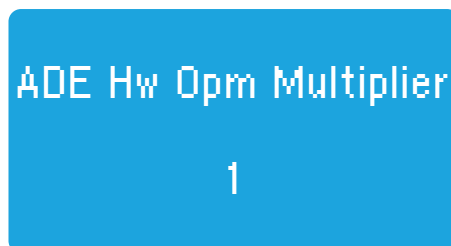

Figure 3.57

Modbus Address

The MODBUS communication settings of device are done in Communication setting menu.



Figure 3.58

With the menu above, a new MODBUS address different from other connected devices is assigned to the device. The values are changed between 0-254 with **DOWN/UP** keys and the wanted address can be given to the device with **SET** key.

Energy Reset

This menu enables to delete the energies that are saved to the device.

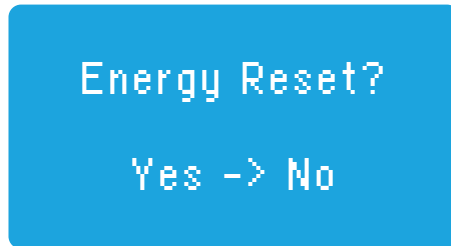

Figure 3.59

If you bring the arrow to Yes with the menu above and confirm with SET key, the saved energies are reset.

Deletion of Power Flow Chart

This menu enables to delete the Power Flow Chart that is saved to the device.

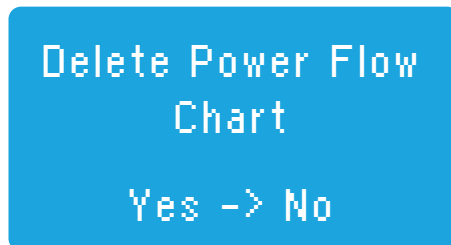

Figure 3.60

If you bring the arrow to Yes with the menu above and confirm with SET key, the saved Power Flow Chart is deleted.

Step Transition Time

The Step Transition Time is set with this menu. This time is determined by the user according to groups of capacitor that are used.



Figure 3.61

When this menu displays on the screen, the step transition time is set with **DOWN / UP** keys.

***NOTE:** The step transition time can be set between 0 and 255 x 10 ms.*

LC Max Opening (L1, L2, L3)

This menu is used to set the percentage of the coil that will be activated. The user sets this value according to the characteristics of the coil being used. It exists in all PFCs with SVC feature.



LC Max Opening (L1,L2,L3)
%100

Figure 3.62

Capacitive Delay Multiplier

It states the delay time of the capacitor when deactivating it in order for the capacitor and the contactors to be long-lasting. The delay time of the capacitor when deactivating it = Reactive Response Time x Capacitive Delay Multiplier.



Cap Delay Multiplier
1

Figure 3.63

NOTE: It should be regarded that if Inductive Power Multiplier and Capacitive Power Multiplier are set high, the reactive response of the relay will be delayed.

Inductive Delay Multiplier

It states the delay time of the capacitor when deactivating it in order for the capacitor and the contactors to be long-lasting. The delay time of the capacitor when deactivating it = Reactive Response Time x Inductive Delay Multiplier.



Ind Delay Multiplier
1

Figure 3.64

NOTE: It should be regarded that if Inductive Power Multiplier and Capacitive Power Multiplier are set high, the reactive response of the relay will be delay

Off Set Step

A load that current transformer does not see (the capacitive effect of long MV cables or inductive loss of power transformer) can be defined to the PFC with 'off set step'. For this process, firstly one of the steps are defined as off set then the convenient value is entered in manual login menu after make a step test to the defined step.

EXAMPLE: The MV cable distance between electric meter and power transformer = 500m Capacitive effect of the cable = 25 kVAR.

In this case, even if the PFC makes $\cos\phi$ as 1, the meter will write capacitive due to capacitive effect of the cable. The reactive difference between meter and PFC can be eliminated by making necessary settings in SMART SVC PFC “Off set” step menu.

Off Set Step Setting

1. An idle step is selected in off set step menu.
2. The demanded value is defined to the selected step in step test menu with the help of manual login.



Figure 3.65

NOTE: The value to be defined to the step that is defined as “Off set” should be; (-) for capacitive loads and (+) for inductive loads.

Off Set Step Extra Information

We can report a value to the PFC that the PFC does not see but the meter sees by associating this value with a step. We name this step as “off set”. This can be any idle step. After entering the number of this step in ‘off set’ step login in the menu, we come to the step test in the menu and make a step test to this step and we enter the value of the step as ‘off set’ value, that the PFC does not see, for each phase in manual screen. We can make ‘off set’ feature activated via any step active and passive with a signal. The generator input of the PFC can be used for this application by making off pin on in the menu. When 220 volt is given to the generator input, ‘off set’ feature becomes active, otherwise it becomes passive. For example; in this way, we can make ‘off set’ value active when cogeneration is deactivated and make passive when it is deactivated.

Rapid Off Set On

If you want this feature to be activated rapidly after choosing “Off Set” step, you should make parameter ‘on’



Figure 3.66

Off Set Output

If you want “Off Set” step to give input when this feature is activated, you should make it ‘on’.

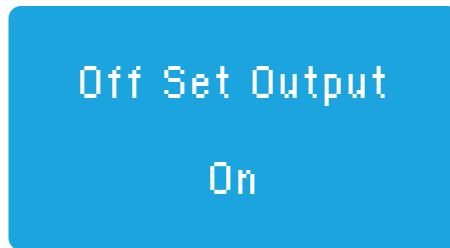

Figure 3.67

Off Set Enter

The value of “Off Set” step can be entered in this screen.

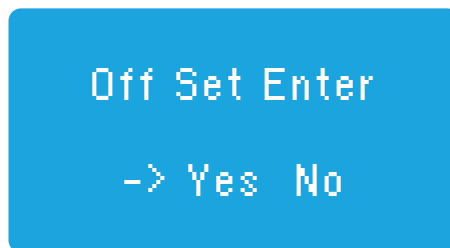

Figure 3.68

Off Set Reactive

“Off Set” step value is entered 100 VAR for each phase.



Figure 3.69

Off Set Pin

If you want to enable or disable generator input pin “Off Set” step, make the parameter ‘on’. If 220 V is reached to the generator pin, the “Off set” state that is activated gets active. When it reaches to 0, the activated “Off set” state is made passive.



Figure 3.70

Inductive Ratio Hysteresis

The system shows tolerance up to the inductive hysteresis value with Inductive Ratio Hysteresis Menu and the necessary capacitor is not done. It is used to extend the life of the board in situations that do not have trouble in terms of punishment. The PFC intervenes in the system to reach inductive limit. If the obtained ratio after intervention is in hysteresis limits, it does not intervene anymore.

EXAMPLE: In case of inductive limit is 5% inductive ratio is 5, if the values stay 5% and 10% after the intervention, the PFC does not intervene anymore.



Figure 3.71

NOTE: Inductive Ratio Hysteresis can be set between 0 and 20.

Capacitive Ratio Hysteresis

With Capacitive Ratio Hysteresis Menu, the system shows tolerance up to capacitive hysteresis value and the necessary power factor correction is not done.

It is used to extend the life of board in situations that do not have trouble in terms of punishment. The PFC intervenes in the system to reach capacitive limit. If the obtained ratio after intervention is in hysteresis limits, it does not intervene anymore.

EXAMPLE: In case of capacitive limit is 12%, capacitive ratio hysteresis 2, the relay will not intervene again if the values after intervention remain between 12% and 14%.



Figure 3.72

NOTE: Capacitive Ratio Hysteresis can be set between 0 and 20.

Response Resolution

Response resolution menu enables to make power factor correction with the wanted accuracy. As the resolution of the answer increases, the accuracy increases; as it decreases, the accuracy decreases. It is not recommended for response resolution to be

high in fast changing loads. In other words, as the response resolution decreases, we find an approximate solution by doing less switching and a definite solution by doing much switching.



Figure 3.73

NOTE: Response resolution can be set between 1 and 60.

Auto Step Test

It exists in 18-step PFCs. The device makes a test automatically in every 15 days when the system is in 'stand by'. This feature is normally closed. Make on to activate it.



Figure 3.74

LC Protection Multiplier

If the power that is demanded from SVC by the system is bigger than reactor power multiplier, the SVC becomes 'off' to protect reactors. This multiplier can be set as 1/2, 2/2, 3/2, 4/2, 5/2, 6/2, 7/2, 8/2. If you want to deactivate the feature, make LC Protection Multiplier 'off'.

EXAMPLE: Suppose that our reactor is 3 kVAr, LC Protection multiplier is 3/2, if the system demands more than $3 \times 3 / 2 = 4.5$ kVAr from the SVC, the SVC is switched off.



Figure 3.75

LC Protection Ratio

If the power demanded from SVC is less than the multiplier of active power drawn from the system, SVC becomes 'off' for not to deactivate reactors unnecessarily. This multiplier is set between 1 and 50. If the feature is not wanted, it is switched off.

EXAMPLE: Suppose that the power demanded from SVC is 3 kVAr, multiplier is 20 and the power drawn from the system is 160 kW. Since SVS's off limit is $3 \times 20 = 60$ kW, SVC will be disabled in our system (for 160 kW) since SVC will be off for larger values of active power.



Figure 3.76

Gen Ind Limit

It exists in all 18-step PFCs. It can have values up to 99. It determines inductive limit when generator is activated. If Gen Ind Limit and Gen Cap Limit are 99 together, power factor correction will be deactivated.

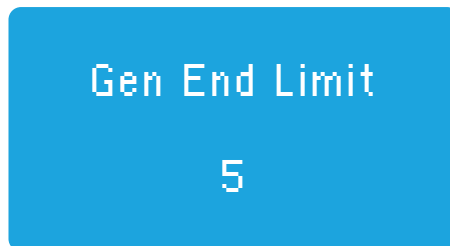

Figure 3.77

Gen Cap Limit

It exists in all 18-step relays. It can have values up to 99. It determines capacitive limit when generator is activated. If Gen Ind Limit and Gen Cap Limit are 99 together, power factor correction will be deactivated.



Figure 3.78

Second Zone Bas

It exist in 18-step PFCs. It exists to use contactor and thyristor switched steps together. Thyristor switching is entered as the parameter to the screen below from which step it starts.



Figure 3.79

Second Zone Multiplier

It exists in all 18-step PFCs. When contactor and thyristor switching steps are used together, the thyristor step determines the speed at which the circuit is engaged.

EXAMPLE: If second zone multiplier is 20, the activation pace of thyristor increases by 20 times compared to the contactor step. So, if discharge time of contactor step is 8 sec, it is $8/20 = 400$ msn in thyristor for step.

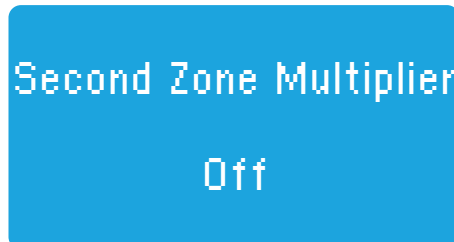

Figure 3.80

DYN Value

It indicates the connection diagram of power transformer. This value is written on tag of the transformer. DYN is the angle difference between the primary and the secondary voltage of the transformer.

EXAMPLE: If DYN=11, the angle between the primary and the secondary voltage is $11 \times 30 = 330$ degrees.



Figure 3.81

Export Energy

It exists in all 18-step PFCs. If you want to make a different power factor correction when the system is energised, make export energy 'on'.



Figure 3.82

In Expr Comp Off

It enables to deactivate power factor correction when the system is in export.



Figure 3.83

In Expr At Imprt

If a phase of the system is in import and the other phase is in export, it compensates the system as if it is in import mode. If you make it 'off', this feature is closed.



Figure 3.84

In Expr Comp Pass

If the system is in export mode, the feature is set to 'on' if you want to switch to stand by.



Figure 3.85

Slayt On

If you want to make the screen stay on a page, make it off.



Figure 3.86

Power Off Set Fac

If you want to synchronize the PFC with another device or you want to make the measured powers over or under % for any reason, this feature is activated.

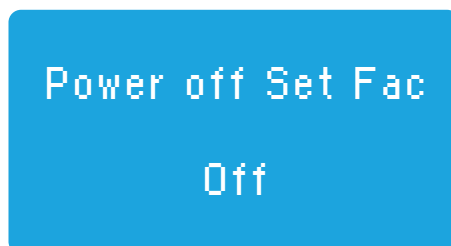

Figure 3.87

AC Off Set Fac L1, L2, L3

It determines the % multiplier of the measured active power to be added.

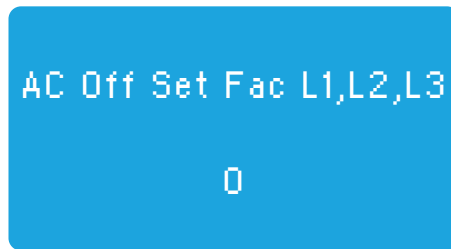

Figure 3.88

EXAMPLE: If parameter is 10, the active power is accepted 10% more than the measured power. So, 80 kW power is accepted as $80 + 80 \times 10\% = 88$. If it is -10, it is reversed. Thus, it is $80 - 80 \times 10\% = 72$.

In Off Set Fac L1, L2, L3

It determines % multiplier of the measured inductive power to be added.



Figure 3.89

EXAMPLE: If parameter is 10, the inductive power is accepted 10% more than the measured power. So, 80 kW power is accepted as $80 + 80 \times 10\% = 88$. If it is -10, it is reversed. Thus, it is $80 - 80 \times 10\% = 72$.

Cp Off Set Fac L1, L2, L3

It determines % multiplier of the measured capacitive power to be added.



Figure 3.90

EXAMPLE: If parameter is 10, the capacitive power is accepted 10% more than the measured power. So, 80 kW power is accepted as $80 + 80 \times 10\% = 88$. If it is -10, it is reversed. Thus, it is $80 - 80 \times 10\% = 72$.

Normal Effect

It stabilizes the solution found with SVC.

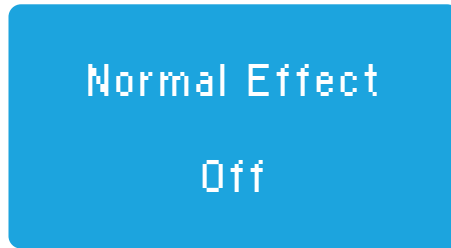

Figure 3.91

Ignore Mode

If one or two of the phases changed directions, it is used to bypass the power factor correction of the wanted direction.



Figure 3.92

LC Force Fac

It used to direct the system to capacitive or move away from capacitive.



Figure 3.93

Auto Transformer Control

In the case of current direction change, it enables to start current transformer test automatically.



Figure 3.94

LC Add Fac

It is used to optimize the use of SVC and capacitor to ensure stability in unbalanced systems.

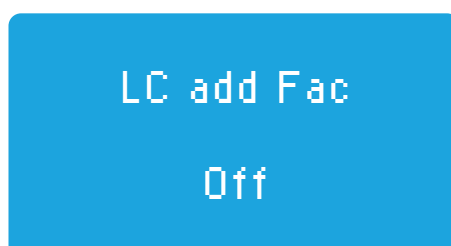

Figure 3.95

Oto Opm Mode

It automatically activates opamps in small currents to increase resolution.

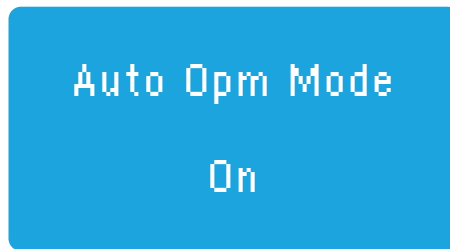

Figure 3.96

Sec Opm Mode

It keeps the multiplier coefficient of opamps in the safe zone.

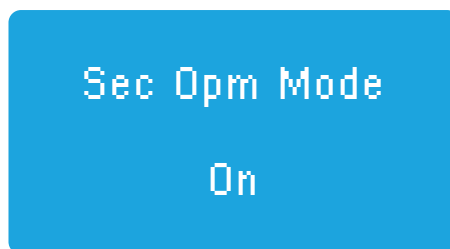

Figure 3.97

Adv Comp Mode

It activates advanced power factor correction mode.



Figure 3.98

Prll Comp Mode

It enables two PFCs to work parallel.



Figure 3.99

Selc Comp Mode

It states parallel working PFC to be master or slave. The phase is entered to alarm input of slave PFC in PFC operating mode. The alarm output is connected to master generator input.

Moreover, the neutral connection of generator input of master PFC is done. The phase is connected to alarm input of master PFC. The alarm output of master PFC is connected to the generator input of slave PFC. The neutral connection of the generator input of master PFC is done.



Figure 3.100

Ade Reset On

It is used to protect energy measurement units in harmonic places from incorrect measurement.



Figure 3.101

Back Light

It exists in 18-step PFCs. If you want the screen to never go off, you must make this feature 'on'.



Figure 3.102

Default Values

All the parameters restored factory settings, except important ones such as Transformer ratio, DYN value.

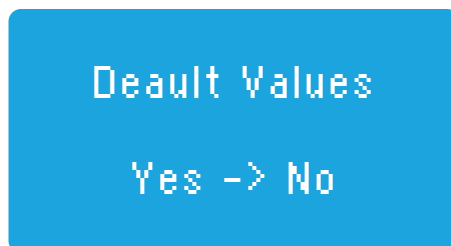

Figure 3.103

4. COMMON ERRORS

4.1. Common Errors and Solution Suggestions

Error Description	Cause of Error	Resolution of Error
The energy is coming on but the device is not working.	The connection sockets are not fully engaged.	Check the connection sockets.
The energy is coming, but the lighting of the screen is flashing.	It occurs as a warning when the PFC exceeds its penalty limit (20% ind, 15% cap).	It should be checked whether the contactors are stuck or whether the steps are appropriate.
Power factor correction supply open, current transformers are buzzing.	Current transformer output terminals are not matched or current transformer output terminals are left open.	Check the current transformer connections by measuring and/or checking by eye/hand. Match the outputs on the PFC.
Although I have matched the current and voltage phases in the current transformer test It gives the warning message "L<1,2,3>Reverse".	The first step capacitors may be defective or two-phase. There are fast changing loads in the system.	Check the capacitor currents with a clamp meter. Move the two-phase or faulty capacitors installed in the first steps to the last steps. Turn off the loads that change suddenly during the test process.
Although I have energized the device, it cannot perform the current transformer test, it constantly gives the "Current Low" warning and activates and deactivates the steps.	The current transformer is not at the network input. There are no capacitors on the steps. Current transformer output terminals are not matched or current transformer output terminals are left open. Step capacitor feeds are taken before the current transformer (current transformer does not see the step currents).	Turn off the fast in and out loads in the system. Check that the current transformers are connected to the first input. Make sure that there is a capacitor or reactor connected to the steps and that the fuse is open and that reactive energy is drawn from all 3 phases.
Current transformer test is finished but capacitor test takes a long time.	There are fast changing loads in the system. Current transformer class greater than 0.5.	Deactivate fast loads in the system. Use current transformers with a class of 0.5.

<p>The inductive LED is on, but the device is not activated.</p>	<p>The steps can be selected large. The PFC may not have recognized the steps.</p>	<p>Analyze the circuit, check the step values by observing the reactive energies flowing through the system from the power flow graph. Make a step test.</p>
<p>The capacitive light is on even though none of the steps are activated. The meter says capacitive</p>	<p>There is capacitive power in the system. There is sticking in the step contactors.</p>	<p>Analyze the system, capacitive load should not exceed the reactor power. Check the step contactors and replace the stuck contactors.</p>
<p>The device activates and deactivates the steps quickly.</p>	<p>The intervention time is low. There are loads coming in and out fast.</p>	<p>If the intervention time is low, it intervenes quickly to the system changes and the intervention slows down as the intervention time increases. If there are loads entering and exiting fast, it responds to the system quickly, of course, it does not reactivate the step without waiting for the discharge time entered from the menu.</p>
<p>The inductive and capacitive ratios shown by the device are incompatible with the ratios measured by the meter.</p>	<p>There may be a defect in the device or meter. Instant measurement was not taken. There may be a load (fixed capacitor, regulator, etc.) between the meter and power factor correction current transformers.</p>	<p>Device power measurement by meter with max there may be deviations of 2-3%. Check your meter. Reset the device's calculated ratios, and compare the ratios again 20 minutes after taking the meter index.</p>
<p>SVC 5.0/10.0/20.0/30.0/60.0 kVAr load driver is overheating.</p>	<p>A reactor larger than the label value is connected. Panel ventilation is not done correctly.</p>	<p>Connect the reactor according to the label value. Make the panel ventilation well, ventilate the panel correctly by designing it to expel hot air out.</p>
<p>The reactors are getting too hot.</p>	<p>Panel ventilation is not done correctly.</p>	<p>Make the panel ventilation well. 70-80°C is normal for the reactor, please do not worry. You can reduce the heat by making good ventilation. Otherwise, the thermals inside the reactor will open and protect the system.</p>
<p>The “Reactors Are Hot” warning appears on the screen.</p>	<p>The reactors are overheating. Panel design is faulty. There is a fault in the connection.</p>	<p>Make reactor ventilation well. Check the thermal connection.</p>

4.2. Operating the Device in the Capacitive Zone

The inductive limit ratio of the device is brought to 1, the capacitive limit is set as required and the device then continues power factor correction by pulling the capacitor until the set capacitive ratio is reached.

4.3. Operating the Device in the Inductive Zone

The device already operates in the inductive region by default. It continues to compensate by pulling the minimum step (no more) to reach the set inductive limit.

4.4. Formatting the Device (Reset)

If it is desired to format the device, after the device is de-energized, the device is energized by pressing and holding the menu button. After the production date of the device appears on the screen, press the ESC button in addition to the menu button, then release the menu button and then release the ESC button. After the format screen appears, select yes and press the menu button.

We recommend that the cable to be used for RS-485 communication be selected according to the table below.

Cable Distance	Recommended Cable	Alternative Recommendation
Up to 30 m	3*0,22 Shielded and Twisted Signal Cable	CAT-5 Ethernet Cable
Over 30 m	3*0,50 Shielded and Twisted Signal Cable	CAT-6 Ethernet Cable

5. MODBUS

5.1. Communication Parameters

Baudrate	19200 bps
Data bits	8
Parity	None
Stop bits	1

5.2. Differences from Standard MODBUS

- Multiple register reading and writing cannot be done.

5.3. Sample Query and Answer

For a device with MODBUS address 5, Phase 1 Active Energy (Consumption) reading;

Query: 0x05 0x03 0x00 0x00 0x00 0x02 0xC5 0x8F

Answer: 0x05 0x03 0x04 0x00 0x00 0x02 0xA4 0xBF 0xC5

For a device with MODBUS address 5, change (write) the Current Transformer Ratio to 30/5;

Query: 0x05 0x06 0x00 0xB4 0x00 0x06 0x48 0x6A

Answer: 0x05 0x06 0x00 0xB4 0x00 0x06 0x48 0x6A

5.4. Additional Explanations

Step Test

The write function (0x06) is applied to the step test address (185). When only one step is to be tested, the low byte of the data to be written takes the value of the step number. For example; In a device with MODBUS address 5, the query we will write to test the 1st step is as follows.

Query: 0x05 0x06 0x00 0xB9 0x00 0x01 0x98 0x6B

Answer: 0x05 0x06 0x00 0xB9 0x00 0x01 0x98 0x6B

If all steps are to be tested, the low byte value is written as 255.

Query: 0x05 0x06 0x00 0xB9 0x00 0xFF 0x19 0xEB

Answer: 0x05 0x06 0x00 0xB9 0x00 0xFF 0x19 0xEB

If only SVC reactors are wanted to be tested; the low byte value is written to 254.

Query: 0x05 0x06 0x00 0xB9 0x00 0xFE 0xD8 0x2B

Answer: 0x05 0x06 0x00 0xB9 0x00 0xFE 0xD8 0x2B

Step Test Cancellation

To cancel the step test, the value 1 is written to address (100) with the write function. No response is received.

Query: 0x05 0x06 0x00 0x64 0x00 0x01 0x08 0x51

Transformer Test

To start the transformer test, the value 1 is written to address (186) with the write function.

Query: 0x05 0x06 0x00 0xBA 0x00 0x01 0x68 0x6B

Answer: 0x05 0x06 0x00 0xBA 0x00 0x01 0x68 0x6B

Transformer Test Cancellation

To cancel the transformer test, the value 1 is written to the address (101) with the write function.

Query: 0x05 0x06 0x00 0x65 0x00 0x01 0x59 0x91

Answer: 0x05 0x06 0x00 0x65 0x00 0x01 0x59 0x91

Step Values

Register addresses between 256-380 give L1, L2, L3 loads for a step in order.

For example, for step 1, registers 256-258-260 are queried with the 0x03 function.

Step Conditions

Address 73 returns a 32-bit number. Starting from index 0, each bit indicates the state of the step as the number of steps increases. If the bit value is 1, the step is activated.

Step Usage

Register addresses 768-785 give the number of switching for each step

SVC Readings

From the end of the step register addresses, 9 pieces of 4 each byte registers, that is, if the relay is 12 steps, the register addresses between 328-344, if it is 18 steps, the register addresses between 364-380 give the SVC values.

Power Flow Graph

Register addresses between 512-655 give L1, L2, L3 power samples, percentage and time values for a step respectively.

For example, for step 1, registers 512-514-516-518-519 are queried with the 0x03 function.

Parameter Name	Address	Data Type	Multiplier	Unit	Function
1. Phase Active Energy (Consumption)	0	Unsigned/32	1	Wh	R
2. Phase Active Energy (Consumption)	2	Unsigned/32	1	Wh	R
3. Phase Active Energy (Consumption)	4	Unsigned/32	1	Wh	R
1. Phase Active Energy (Production)	6	Unsigned/32	1	Wh	R
2. Phase Active Energy (Production)	8	Unsigned/32	1	Wh	R
3. Phase Active Energy (Production)	10	Unsigned/32	1	Wh	R
1.Phase Inductive Energy	12	Unsigned/32	1	VARh	R
2.Phase Inductive Energy	14	Unsigned/32	1	VARh	R
3.Phase Inductive Energy	16	Unsigned/32	1	VARh	R
1. Phase Capacitive Energy	18	Unsigned/32	1	VARh	R
2. Phase Capacitive Energy	20	Unsigned/32	1	VARh	R
3. Phase Capacitive Energy	22	Unsigned/32	1	VARh	R
1. Phase Active Power	24	Signed/32	1	W	R
2. Phase Active Power	26	Signed/32	1	W	R
3. Phase Active Power	28	Signed/32	1	W	R
1. Phase Inductive Power	30	Signed/32	1	VAR	R

2.Phase Inductive Power	32	Signed/32	1	VAr	R
3.Phase Inductive Power	34	Signed/32	1	VAr	R
1.Phase Capacitive Power	36	Signed/32	1	VAr	R
2.Phase Capacitive Power	38	Signed/32	1	VAr	R
3.Phase Capacitive Power	40	Signed/32	1	VAr	R
1. Phase Cos ϕ	42	Signed/16	100	%	R
2. Phase Cos ϕ	43	Signed/16	100	%	R
3. Phase Cos ϕ	44	Signed/16	100	%	R
Reached Inductive Percentage	45	Unsigned/16	10	%	R
Reached Capacitive Percentage	46	Unsigned/16	10	%	R
1. Phase Frequency	47	Unsigned/16	1	Hz	R
2. Phase Frequency	48	Unsigned/16	1	Hz	R
3. Phase Frequency	49	Unsigned/16	1	Hz	R
1. Phase THDI	50	Unsigned/16	1	%	R
2. Phase THDI	51	Unsigned/16	1	%	R
3. Phase THDI	52	Unsigned/16	1	%	R
1.Phase SVC Opening Percentage	53	Unsigned/16	10	%	R
2.Phase SVC Opening Percentage	54	Unsigned/16	10	%	R
3.Phase SVC Opening Percentage	55	Unsigned/16	10	%	R

1. Phase Voltage	56	Unsigned/16	1	V	R
2. Phase Voltage	57	Unsigned/16	1	V	R
3. Phase Voltage	58	Unsigned/16	1	V	R
1. Phase Current	59	Unsigned/32	100	A	R
2. Phase Current	61	Unsigned/32	100	A	R
3. Phase Current	63	Unsigned/32	100	A	R
Serial Number	70	Char/48	1		R
Device Status	72	Byte/8	1		R
Step Status	73	Unsigned/32	1		R
Step Test Cancellation	100	Unsigned/16	1		W
Transformer Test Cancellation	101	Unsigned/16	1		W
Reactive Response Time	150	Unsigned/16	100	Sn	R/W
Normally Response Time	151	Unsigned/16	100	Sn	R/W
SVC Response Time	153	Unsigned/16	100	Sn	R/W
Capacitor Discharge Time	154	Unsigned/16	100	Sn	R/W
Energy Integral Time	158	Unsigned/16	100	Sn	R/W
ADE Opamp Multiplier	159	Unsigned/16	1		R/W
ADE Hw Opamp Multiplier	161	Unsigned/16	1		R/W
Inductive Hysteresis	166	Unsigned/16	1		R/W

Capacitive Hysteresis	167	Unsigned/16	1		R/W
Response Resolution	168	Unsigned/16	1		R/W
Inductive Limit	169	Unsigned/16	1		R/W
Capacitive Limit	170	Unsigned/16	1		R/W
LC Offset L1	171	Signed/16	1		R/W
LC Offset L2	172	Signed/16	1		R/W
LC Offset L3	173	Signed/16	1		R/W
1. SVC Max Opening Percentage	177	Unsigned/16	1		R/W
2. SVC Max Opening Percentage	178	Unsigned/16	1		R/W
3. SVC Max Opening Percentage	179	Unsigned/16	1		R/W
Current Transformer Ratio	180	Unsigned/16	1		R/W
Voltage Transformer Ratio	181	Unsigned/16	1		R/W
Step Test	185	Unsigned/16	1		W
Transformer Test	186	Unsigned/16	1		W
Step Values					
1. Step Q1	256	Signed/32	1		R
1. Step Q2	258	Signed/32	1		R
1. Step Q3	260	Signed/32	1		R

2. Step Q1	262	Signed/32	1		R
2. Step Q2	264	Signed/32	1		R
2. Step Q3	266	Signed/32	1		R
3. Step Q1	268	Signed/32	1		R
3. Step Q2	270	Signed/32	1		R
3. Step Q3	272	Signed/32	1		R
4. Step Q1	274	Signed/32	1		R
4. Step Q2	276	Signed/32	1		R
4. Step Q3	278	Signed/32	1		R
5. Step Q1	280	Signed/32	1		R
5. Step Q2	282	Signed/32	1		R
5. Step Q3	284	Signed/32	1		R
6. Step Q1	286	Signed/32	1		R
6. Step Q2	288	Signed/32	1		R
6. Step Q3	290	Signed/32	1		R
7. Step Q1	292	Signed/32	1		R
7. Step Q2	294	Signed/32	1		R
7. Step Q3	296	Signed/32	1		R
8. Step Q1	298	Signed/32	1		R

8. Step Q2	300	Signed/32	1		R
8. Step Q3	302	Signed/32	1		R
9. Step Q1	304	Signed/32	1		R
9. Step Q2	306	Signed/32	1		R
9. Step Q3	308	Signed/32	1		R
10. Step Q1	310	Signed/32	1		R
10. Step Q2	312	Signed/32	1		R
10. Step Q3	314	Signed/32	1		R
11. Step Q1	316	Signed/32	1		R
11. Step Q2	318	Signed/32	1		R
11. Step Q3	320	Signed/32	1		R
12. Step Q1	322	Signed/32	1		R
12. Step Q2	324	Signed/32	1		R
12. Step Q3	326	Signed/32	1		R
13. Step Q1	328	Signed/32	1		R
13. Step Q2	330	Signed/32	1		R
13. Step Q3	332	Signed/32	1		R
14. Step Q1	334	Signed/32	1		R
14. Step Q2	336	Signed/32	1		R

14. Step Q3	338	Signed/32	1		R
15. Step Q1	340	Signed/32	1		R
15. Step Q2	342	Signed/32	1		R
15. Step Q3	344	Signed/32	1		R
16. Step Q1	346	Signed/32	1		R
16. Step Q2	348	Signed/32	1		R
16. Step Q3	350	Signed/32	1		R
17. Step Q1	352	Signed/32	1		R
17. Step Q2	354	Signed/32	1		R
17. Step Q3	356	Signed/32	1		R
18. Step Q1	358	Signed/32	1		R
18. Step Q2	360	Signed/32	1		R
18. Step Q3	362	Signed/32	1		R
1. SVC Q1	364	Signed/32	1		R
1. SVC Q2	366	Signed/32	1		R
1. SVC Q3	368	Signed/32	1		R
2. SVC Q1	370	Signed/32	1		R
2. SVC Q2	372	Signed/32	1		R
2. SVC Q3	374	Signed/32	1		R

3. SVC Q1	376	Signed/32	1		R
3. SVC Q2	378	Signed/32	1		R
3. SVC Q3	380	Signed/32	1		R
Power Flow Graph Examples					
1. Example Q1	512	Signed/32	1		R
1. Example Q2	514	Signed/32	1		R
1. Example Q3	516	Signed/32	1		R
1. Sample Percentage	518	Unsigned/16	1		R
1. Sample Time	519	Unsigned/16	1		R
2. Example Q1	520	Signed/32	1		R
2. Example Q2	522	Signed/32	1		R
2. Example Q3	524	Signed/32	1		R
2. Sample Percentage	526	Unsigned/16	1		R
2. Sample Time	527	Unsigned/16	1		R
3. Example Q1	528	Signed/32	1		R
3. Example Q2	530	Signed/32	1		R
3. Example Q3	532	Signed/32	1		R
3. Sample Percentage	534	Unsigned/16	1		R
3. Sample Time	535	Unsigned/16	1		R

4. Example Q1	536	Signed/32	1		R
4. Example Q2	538	Signed/32	1		R
4. Example Q3	540	Signed/32	1		R
4. Sample Percentage	542	Unsigned/16	1		R
4. Sample Time	543	Unsigned/16	1		R
5. Example Q1	544	Signed/32	1		R
5. Example Q2	546	Signed/32	1		R
5. Example Q3	548	Signed/32	1		R
5. Sample Percentage	550	Unsigned/16	1		R
5. Sample Time	551	Unsigned/16	1		R
6. Example Q1	552	Signed/32	1		R
6. Example Q2	554	Signed/32	1		R
6. Example Q3	556	Signed/32	1		R
6. Sample Percentage	558	Unsigned/16	1		R
6. Sample Time	559	Unsigned/16	1		R
7. Example Q1	560	Signed/32	1		R
7. Example Q2	562	Signed/32	1		R
7. Example Q3	564	Signed/32	1		R
7. Sample Percentage	566	Unsigned/16	1		R





7. Sample Time	567	Unsigned/16	1		
8. Example Q1	568	Signed/32	1		
8. Example Q2	570	Signed/32	1		
8. Example Q3	572	Signed/32	1		
8. Sample Percentage	574	Unsigned/16	1		
8. Sample Time	575	Unsigned/16	1		
9. Example Q1	576	Signed/32	1		
9. Example Q2	578	Signed/32	1		
9. Example Q3	580	Signed/32	1		
9. Sample Percentage	582	Unsigned/16	1		
9. Sample Time	583	Unsigned/16	1		
10. Example Q1	584	Signed/32	1		
10. Example Q2	586	Signed/32	1		
10. Example Q3	588	Signed/32	1		
10. Sample Percentage	590	Unsigned/16	1		
10. Sample Time	591	Unsigned/16	1		
11. Example Q1	592	Signed/32	1		
11. Example Q2	594	Signed/32	1		
11. Example Q3	596	Signed/32	1		

11. Sample Percentage	598	Unsigned/16	1		
11. Sample Time	599	Unsigned/16	1		
12. Example Q1	600	Signed/32	1		
12. Example Q2	602	Signed/32	1		
12. Example Q3	604	Signed/32	1		
12. Sample Percentage	606	Unsigned/16	1		
12. Sample Time	607	Unsigned/16	1		
13. Example Q1	608	Signed/32	1		
13. Example Q2	610	Signed/32	1		
13. Example Q3	612	Signed/32	1		
13. Sample Percentage	614	Unsigned/16	1		
13. Sample Time	615	Unsigned/16	1		
14. Example Q1	616	Signed/32	1		
14. Example Q2	618	Signed/32	1		
14. Example Q3	620	Signed/32	1		
14. Sample Percentage	622	Unsigned/16	1		
14. Sample Time	623	Unsigned/16	1		
15. Example Q1	624	Signed/32	1		
15. Example Q2	626	Signed/32	1		

15. Example Q3	628	Signed/32	1		
15. Sample Percentage	630	Unsigned/16	1		
15. Sample Time	631	Unsigned/16	1		
16. Example Q1	632	Signed/32	1		
16. Example Q2	634	Signed/32	1		
16. Example Q3	636	Signed/32	1		
16. Sample Percentage	638	Unsigned/16	1		
16. Sample Time	639	Unsigned/16	1		
17. Example Q1	640	Signed/32	1		
17. Example Q2	642	Signed/32	1		
17. Example Q3	644	Signed/32	1		
17. Sample Percentage	646	Unsigned/16	1		
17. Sample Time	647	Unsigned/16	1		
18. Example Q1	648	Signed/32	1		
18. Example Q2	650	Signed/32	1		
18. Example Q3	652	Signed/32	1		
18. Sample Percentage	654	Unsigned/16	1		
18. Sample Time	655	Unsigned/16	1		

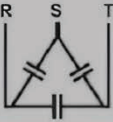
Step Usage					
1. Step Usage	768	Unsigned/16	1		
2. Step Usage	769	Unsigned/16	1		
3. Step Usage	770	Unsigned/16	1		
4. Step Usage	771	Unsigned/16	1		
5. Step Usage	772	Unsigned/16	1		
6. Step Usage	773	Unsigned/16	1		
7. Step Usage	774	Unsigned/16	1		
8. Step Usage	775	Unsigned/16	1		
9. Step Usage	776	Unsigned/16	1		
10. Step Usage	777	Unsigned/16	1		
11. Step Usage	778	Unsigned/16	1		
12. Step Usage	779	Unsigned/16	1		
13. Step Usage	780	Unsigned/16	1		
14. Step Usage	781	Unsigned/16	1		
15. Step Usage	782	Unsigned/16	1		
16. Step Usage	783	Unsigned/16	1		
17. Step Usage	784	Unsigned/16	1		
18. Step Usage	785	Unsigned/16	1		

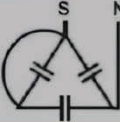
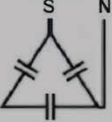
6. CAPACITOR TRANSFORMATION TABLE

					
Total Capacitor Power (kVAr) Q	Three-Phase Connection (Q)	Two-Phase Connection (Q/2)	Phase-Neutral Bridge Connection (2Q/9)	Phase-Neutral Connection (Q/6)	Two-Phase Bridge Connection (2Q/3)
0,5	3 x 0,17	2 x 0,13	1 x 0,11	1 x 0,08	2 x 0,17
1,0	3 x 0,33	2 x 0,25	1 x 0,22	1 x 0,17	2 x 0,33
1,5	3 x 0,5	2 x 0,37	1 x 0,33	1 x 0,25	2 x 0,5
2,5	3 x 0,83	2 x 0,63	1 x 0,55	1 x 0,41	2 x 0,83
5,0	3 x 1,67	2 x 1,25	1 x 1,11	1 x 0,83	2 x 1,67
7,5	3 x 2,5	2 x 1,87	1 x 1,67	1 x 1,25	2 x 2,5
10	3 x 3,33	2 x 2,5	1 x 2,22	1 x 1,67	2 x 3,33
15	3 x 5	2 x 3,75	1 x 3,33	1 x 2,5	2 x 5
20	3 x 6,67	2 x 5	1 x 4,44	1 x 3,33	2 x 6,67
25	3 x 8,33	2 x 6,25	1 x 5,56	1 x 4,17	2 x 8,33
30	3 x 10	2 x 7,5	1 x 6,67	1 x 5	2 x 10