

# Capacitive Static Contactor User Manual



**ADDRESS: Ikitelli OSB Mah. Cevre 14.  
Blok Sok. Telas Blok Dis Kapi No: 1  
Kat: 1-2 Basaksehir/Istanbul**

**Phone: +90 212 438 80 24  
Fax: +90 212 438 80 25**

**info@gruparge.com**

# CONTENTS

PROPER USE AND SAFETY REQUIREMENTS .....	3
1. INPUT .....	4
1.1. General Features .....	4
1.2. Key Features .....	4
1.3. Technical Features .....	5
1.4. Technical Drawing .....	6
1.4.1. KSK 10 Technical Drawing .....	6
1.4.2. KSK 20 Technical Drawing .....	6
1.4.3. KSK 30 Technical Drawing .....	6
1.4.4. KSK 15-25 Technical Drawing .....	7
1.4.5. KSK 50 Technical Drawing .....	7
1.4.6. KSK 80 Technical Drawing .....	7
1.4.7. KSK 100 Technical Drawing .....	7
1.5. Connection Diagram .....	8
1.5.1. Capacitive Static Contactor T2 Connection .....	8
1.5.2. Capacitive Static Contactor T3 Connection .....	8
1.5.3. Capacitive Static Contactor Single Phase T3 Connection .....	8

## PROPER USE AND SAFETY REQUIREMENTS



Cut all the power when connecting and disconnecting the device to a panel.



Do not clean the device with a solvent or similar material. Only use a dry cloth.



Please do not intervene to the device when a technical problem is encountered and get in contact with a technical service within the shortest time.



If the warnings are not taken into account, our company or the authorized dealer shall not be held responsible for the negative consequences.



Do not dispose in the trash, the device must be delivered to the collection centers (electronic device recycling centers). It should be recycled or disposed of without harming human health and environment.



The installation, assembly, activation and operation of the device should be done and used by only expert professionals and in accordance with safety regulations and instructions.

# 1. INPUT

## 1.1. General Features

It is used for switching capacitors in compensation systems. Static contactors prevent high switching currents by switching when capacitor voltage and bus voltage are equalized. Furthermore, it provides to meet the reactive needs of fast loads by switching very fast without waiting for the capacitor discharge time.

In enterprises where reactive changes are fast, contactor systems are insufficient to respond to the need for compensation. In the compensation of such enterprises, it is possible to respond to rapidly changing loads by switching with thyristors instead of switching with mechanical contactors in classical systems.

In thyristor systems, since the capacitors are activated at zero crossings, the necessity to wait for discharge times is eliminated. In addition, since the current drawn when the capacitors are first switched on is minimal, it is possible to switch on and off at a high speed.

## 1.2. Key Features

- **Nominal Voltage:** 230 V / 400 V
- **Nominal Frequency:** 50 / 60 Hz
- **Maximum Operating Voltage:** 400 V
- **Control Voltage:** 9 - 30 V DC
- **Ambient Temperature:** -10 C° / +55 C°
- **Protection Class:** IP00
- **Response Time:** 20 ms
- **Humidity:** 95%
- **Fan Control:** @50°C NO
- **Module Protection:** @ 95°C NC
- Led Indicators for Line Input, Outputs and Control Signals
- Led Indicator to Right Mounting Direction
- IGBT-Controlled Internal Discharge Resistors

## 1.3. Technical Features

Product Code	Product Name	Product Description	Voltage (V)	Nominal Cable Cross-Section (mm <sup>2</sup> )	Nominal Fuse Current (A)	Cooling		Mounting Direction LED	Input, Output, and Trigger Control LEDs	Internal Thermal Protection	External Thermal Protection	Dimensions W x H x D (mm)
						With Fan	Fanless Natural					
GA2201	KSK 10T3*	10 kVAr CAP. STATIC CON. 3 TRIS.	230/400	3(1x4)	25		✓	✓	✓	✓	✓	167 x 130 x 131
GA2204	KSK 20T3*	20 kVAr CAP. STATIC CON. 3 TRIS	230/400	3(1x6)	50		✓	✓	✓	✓	✓	167 x 158 x 131
GA2213	KSK 30T3*	30 kVAr CAP. STATIC CON. 3 TRIS	230/400	3(1x16)	80		✓	✓	✓	✓	✓	165 x 200 x 144
GA2202	KSK 15T2	15 kVAr CAP. STATIC CON.	400	3(1x4)	40		✓	✓	✓	✓	✓	167 x 163 x 138
GA2205	KSK 25T2	25 kVAr CAP. STATIC CON.	400	3(1x10)	63		✓	✓	✓	✓	✓	167 x 163 x 138
GA2207	KSK 50T2	50 kVAr CAP. STATIC CON.	400	3(1x35)	125	✓		✓	✓	✓	✓	167 x 210 x 141
GA2203	KSK 15T2D	15 kVAr CAP. STATIC CON. DISCHARGE RESISTANT	400	3(1x4)	40		✓	✓	✓	✓	✓	167 x 163 x 138
GA2206	KSK 25T2D	25 kVAr CAP. STATIC CON. DISCHARGE RESISTANT	400	3(1x10)	63		✓	✓	✓	✓	✓	167 x 163 x 138
GA2208	KSK 50T2D	50 kVAr CAP. STATIC CON. DISCHARGE RESISTANT	400	3(1x35)	125	✓		✓	✓	✓	✓	167 x 210 x 141
GA2210	KSK 80T2D	80 kVAr CAP. STATIC CON. DISCHARGE RESISTANT	400	3(1x50)	200	✓		✓	✓	✓	✓	167 x 275 x 135
GA2212	KSK 100T2D	100 kVAr CAP. STATIC CON. DISCHARGE RESISTANT	400	3(1x70)	250	✓		✓	✓	✓	✓	165 x 253 x 148

**\*For three-phase capacitors, a static contactor with 2 thyristors, a static contactor with 3 thyristors must be preferred for single-phase capacitors.**

50, 80 and 100 kVAr capacitive static contactors are fan cooled. All static contactors have NC (Normally closed) thermal control. Capacitive static contactors must be used in conjunction with a harmonic filter or current limiting reactor. In panels where capacitive static contactors are used, LV surge arrester must be used.

### **In what situations and why should the discharge resistor be used?**

It is recommended to use it in all applications with harmonic filters. In order for the capacitor to be put back into operation in a short time after disconnection, the discharge resistor must be used. The discharge resistance can also be applied externally.

### **What is the advantage of products with an internal discharge resistor?**

In externally applied discharge resistor solutions, the discharge resistors are constantly under voltage while the capacitors are in operation. In this case, the resistors increase active losses and board temperature. Discharge resistors integrated in the IGBT and the drivers can discharge the capacitor in less than 150 ms after the capacitor is removed from the circuit. Discharge the capacitor and leave the circuit. When the capacitor is in the circuit, the resistors are not connected to the line.

## 1.4. Technical Drawing

### 1.4.1. Capacitive Static Contactors KSK 10

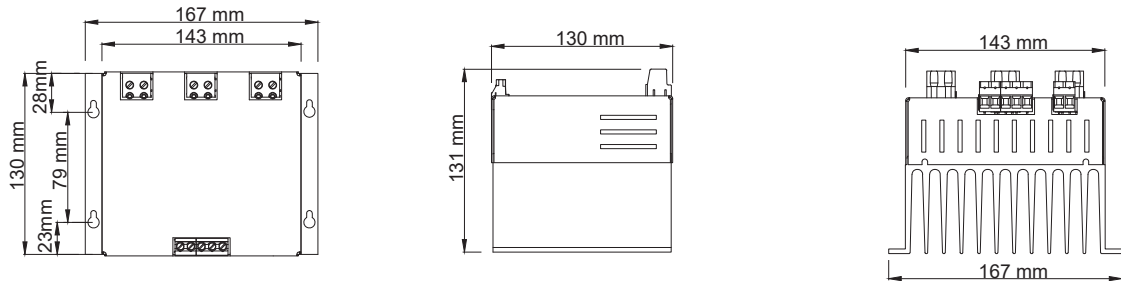

### 1.4.2. Capacitive Static Contactors KSK 20

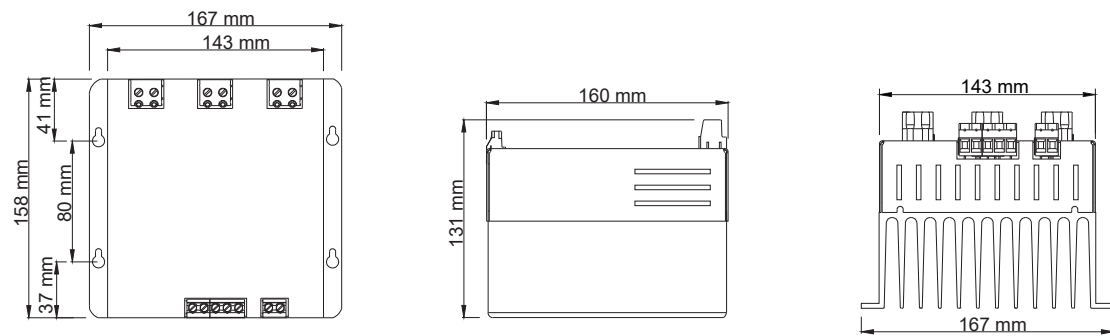

### 1.4.3. Capacitive Static Contactors KSK 30

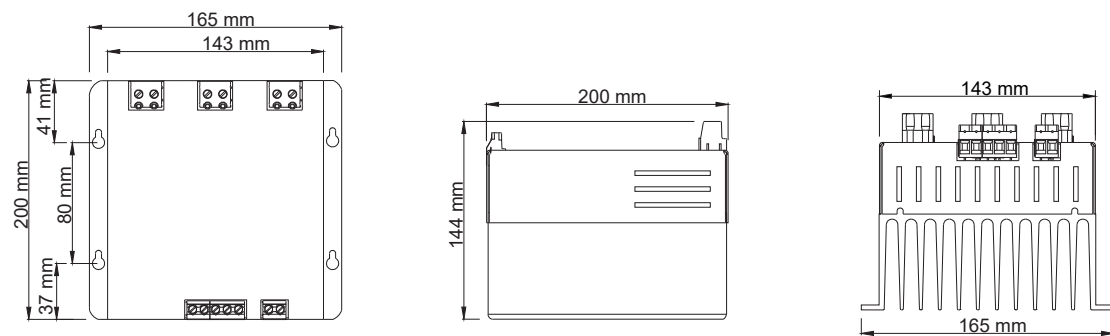

#### 1.4.4. Capacitive Static Contactors KSK 15-25

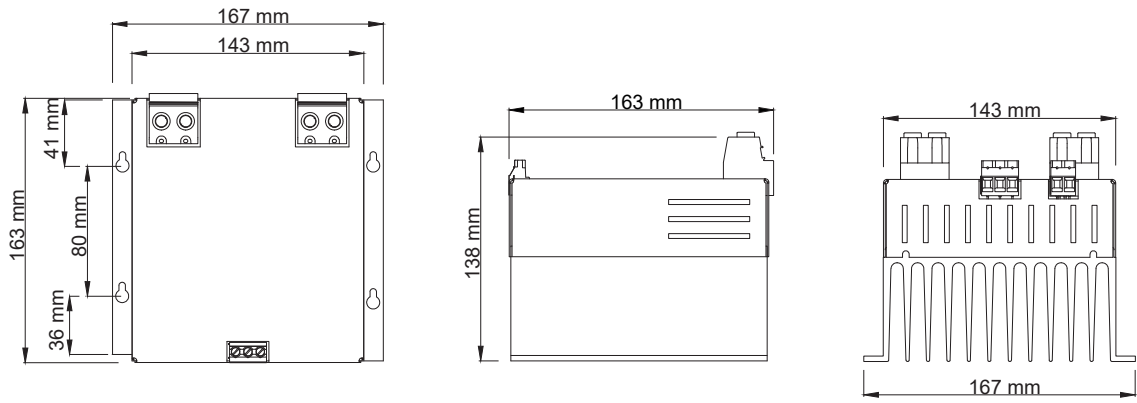

#### 1.4.5. Capacitive Static Contactors KSK 50

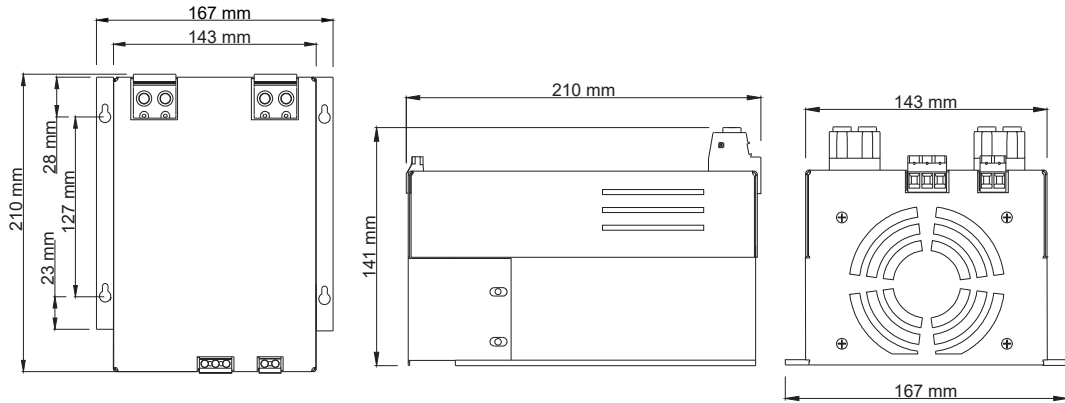

#### 1.4.6. Capacitive Static Contactors KSK 80

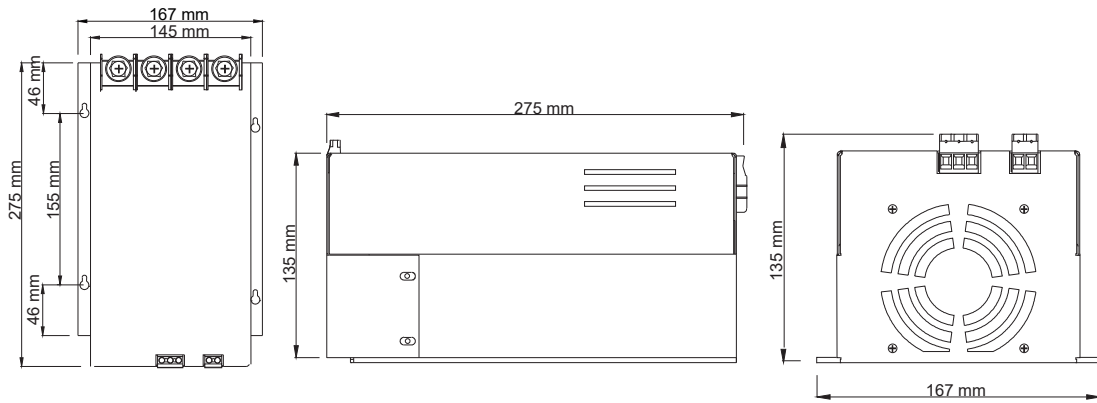

#### 1.4.7. Capacitive Static Contactors KSK 100

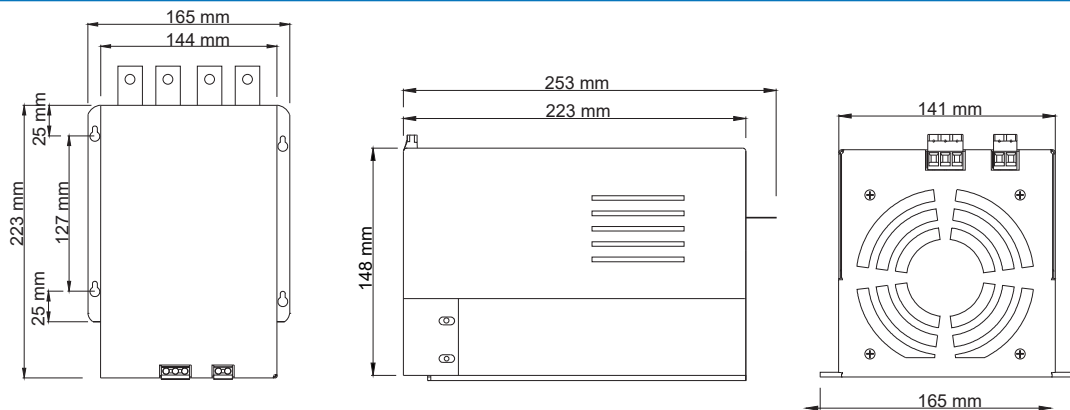

# 1.5. Connection Diagram

## 1.5.1. Capacitive Static Contactor T2 Connection

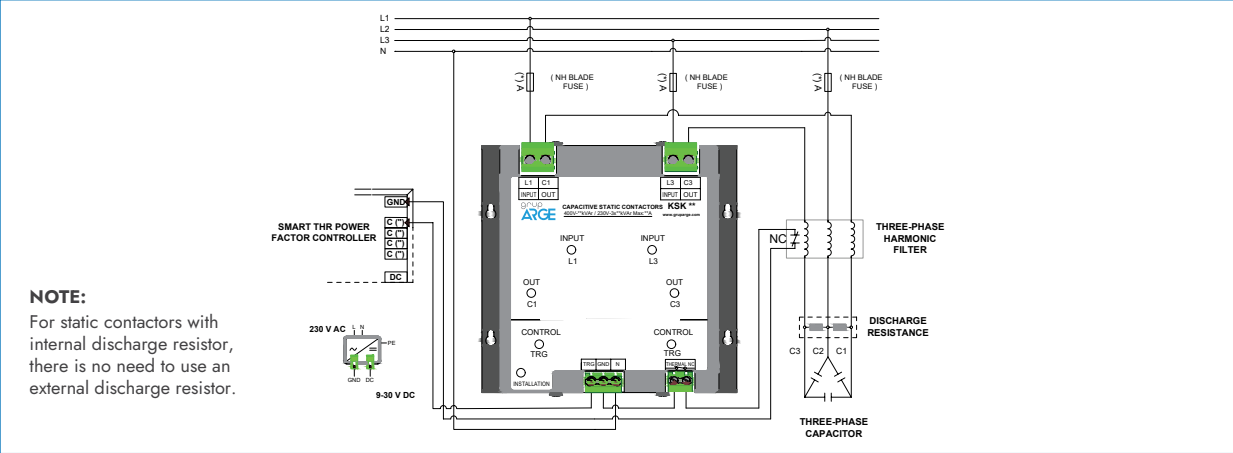

## 1.5.2. Capacitive Static Contactor T3 Connection

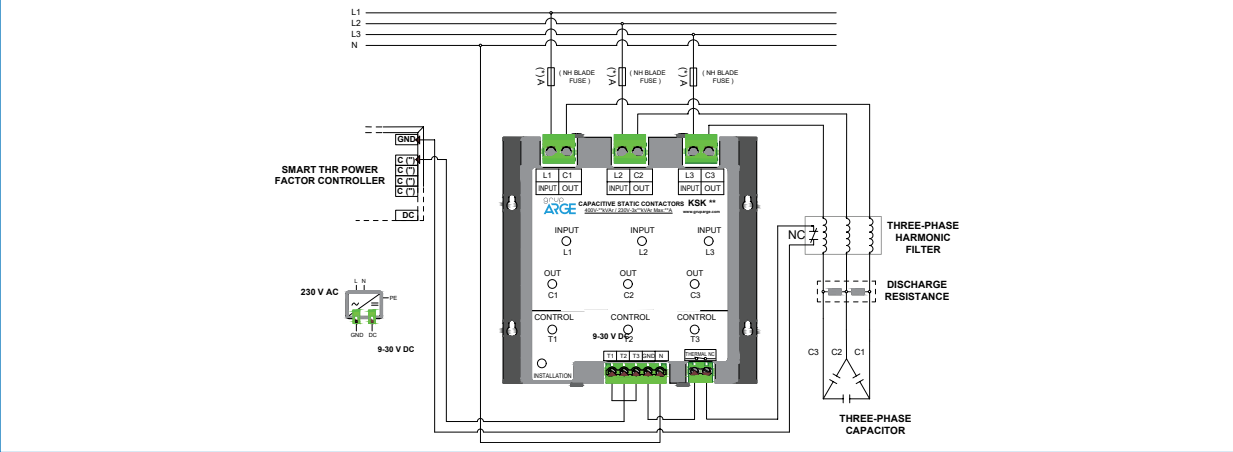

## 1.5.3. Capacitive Static Contactor Single Phase T3 Connection

